

## IPERCOM DESKTOP SWITCHBOARD

Ref. 1060/42

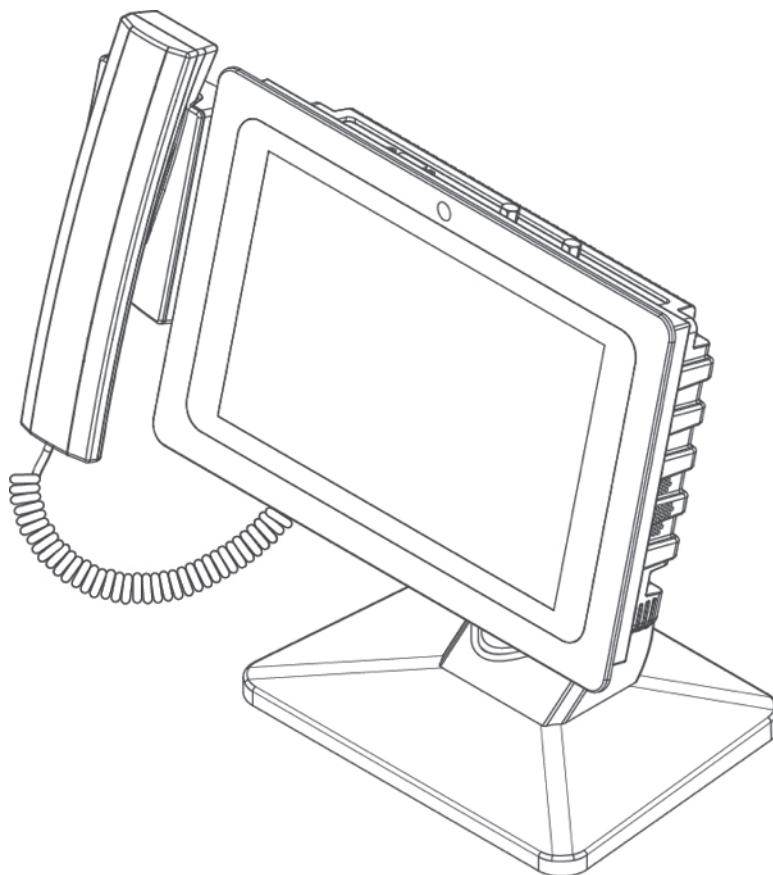

**USER BOOKLET**

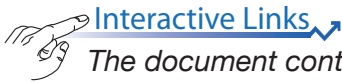

## INDEX

<a href="#">1 GENERAL DESCRIPTION</a>	3
<a href="#">2 FIRST START-UP</a>	3
<a href="#">3 USER INTERFACE</a>	4
<a href="#">4 OPERATING MODES</a>	5
<a href="#">4.1 Logout / Device Lock / Device Restart / Device Shutdown</a>	5
<a href="#">4.2 Switchboard in Night mode</a>	6
<a href="#">4.3 Switchboard in Day mode</a>	7
<a href="#">5 SWITCHBOARD USE</a>	8
<a href="#">5.1 Call received from a calling station</a>	8
<a href="#">5.2 Call received from an apartment station</a>	10
<a href="#">5.3 Receiving a call from a calling station and forwarding to a user (concierge service)</a>	13
<a href="#">5.4 Call to a user with code</a>	15
<a href="#">5.5 Call to a user with the address book</a>	18
<a href="#">5.5.1 User search by name</a>	19
<a href="#">5.5.2 User search by apartment</a>	20
<a href="#">5.5.3 Call to a user by address book</a>	20
<a href="#">5.5.4 Sending chat message</a>	21
<a href="#">5.5.5 Switchboard search</a>	22
<a href="#">5.5.6 Contact search</a>	22
<a href="#">5.5.7 Search by topological code</a>	23
<a href="#">5.5.8 Chat list</a>	23
<a href="#">5.6 Receiving a call from a user and forwarding it to another user</a>	24
<a href="#">5.7 Receiving a call from an outdoor or apartment station and forwarding it to another switchboard</a>	26
<a href="#">5.8 Top control bar</a>	30
<a href="#">5.8.1 Alarms</a>	30
<a href="#">5.8.2 Opened doors</a>	33
<a href="#">5.8.3 Calls memory</a>	34
<a href="#">5.8.4 Address book</a>	37
<a href="#">5.8.5 Text messages</a>	38
<a href="#">5.8.6 Diagnostics</a>	38
<a href="#">5.8.7 Other options</a>	43
<a href="#">5.9 External cameras (RTSP)</a>	61
<a href="#">5.9.1 Access control</a>	63
<a href="#">6 PROBLEM SOLVING</a>	64
<a href="#">6.1 Mismatch between software versions of devices</a>	64
<a href="#">6.2 Server unreachable</a>	64
<a href="#">APPENDIX A: Configuring call forwarding function</a>	65
<a href="#">APPENDIX B: Configuring call forwarding function in ipercom systems in ipercloud mode</a>	75
<a href="#">APPENDIX C: Call to several switchboard applications each connected to a callme app</a>	76

## 1 GENERAL DESCRIPTION

The Ipercom switchboard was designed and made to allow the concierge staff of a building to manage all the typical functions of a switchboard station, such as handling calls from the call station, calls to and from apartments, and access control.

## 2 FIRST START-UP

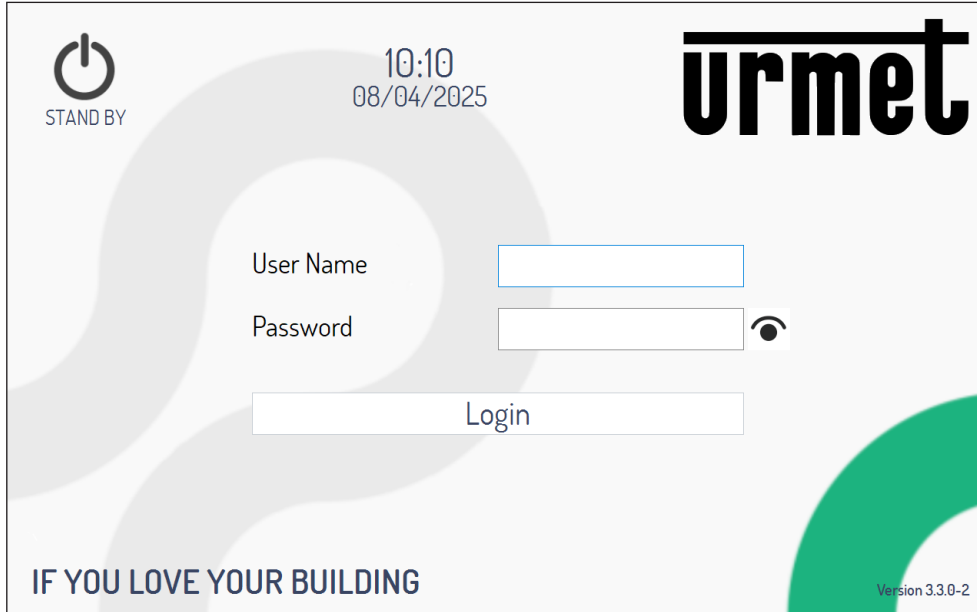

On first start-up, having configured the switchboard station, the access credentials will be requested through the following login window:



The login window features a power icon with 'STAND BY' text, a digital clock showing '10:10' and the date '08/04/2025', and the 'urmet' logo. It contains two input fields for 'User Name' and 'Password', with an eye icon for password visibility. A 'Login' button is positioned below the password field. The slogan 'IF YOU LOVE YOUR BUILDING' is at the bottom left, and 'Version 3.3.0-2' is at the bottom right.

 For the creation of users with their passwords for using the device, please refer to the [IPerCom system installer's technical manual](#) (Ver. 3.2).

After entering the login credentials and pressing the “Login” button, the user interface will be displayed, a detailed description of which is provided in the next section.

The icon  next to the password entry box allows you to view the password you entered. If pressed the icon changes to the following  and the password entered is no longer displayed.

If the switchboard is not yet configured on the Ipercom network, the following screen will be displayed:

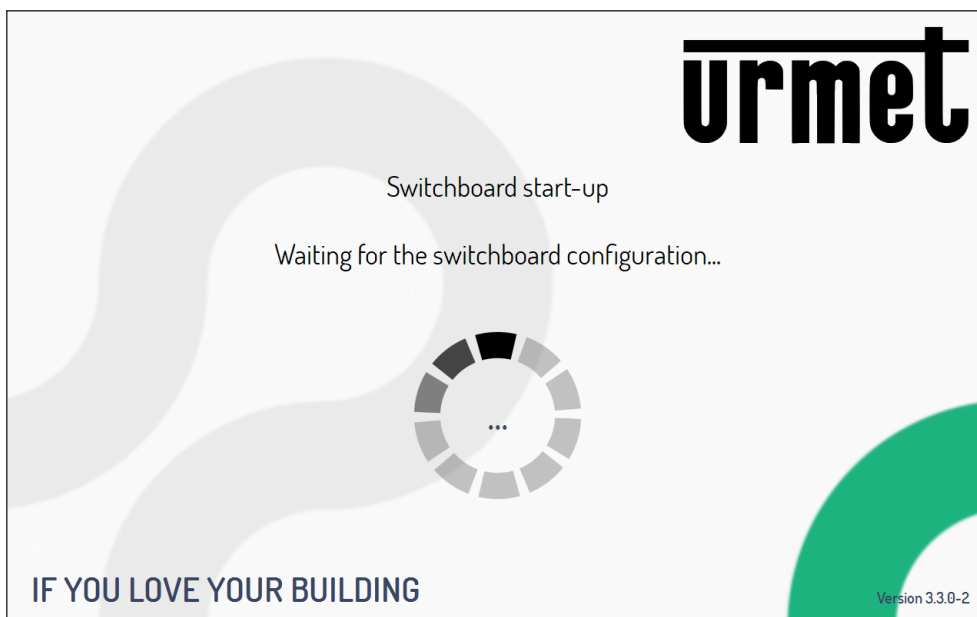

 For configuration of the device, refer to [IPerCom system installer's technical manual](#) (Ver. 3.2).

### 3 USER INTERFACE

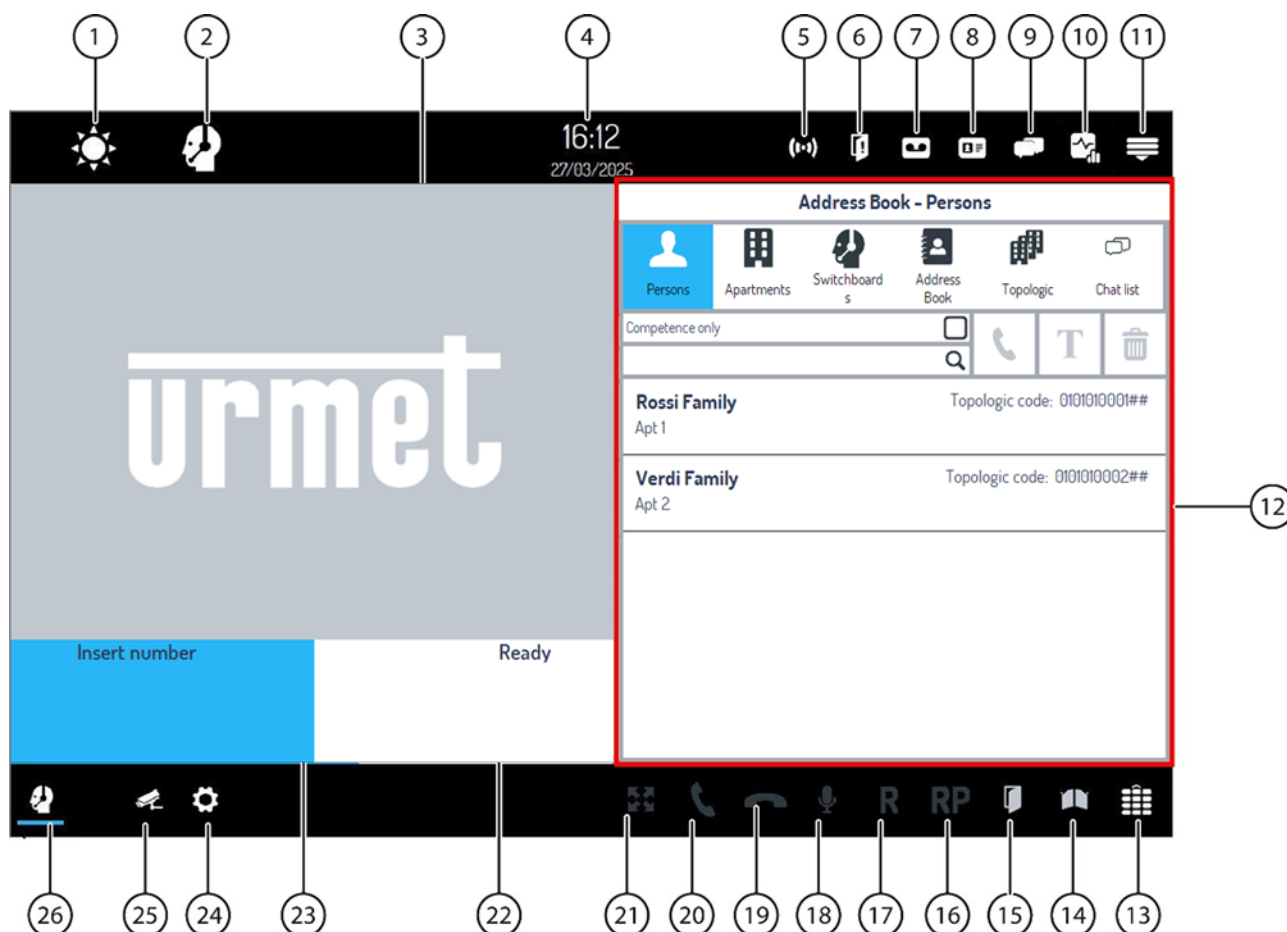



1. Switchboard status display
2. Call transfer status display
3. Video picture area
4. Date and time indication
5. Alarm button (acoustic warning and blinking in case of alarms in progress)
6. Management button of open door signals
7. Missed call list button (blinking in case of missed calls)
8. Address book button
9. Chat button (acoustic warning and blinking in case of incoming message which has not been read)
10. Diagnostic button (audible and flashing in case of malfunctioning devices)
11. "Other options" display button
12. Contextual section (the section changes based on the button pressed in the top section)
13. Hide/show keyboard button
14. Open gate button
15. Open pedestrian door button
16. Last contact called redial button
17. Call hold/resume button
18. Mute microphone button
19. Call closure button
20. Button to make and answer call
21. Pulsante per l'ingrandimento/riduzione dell'immagine durante la chiamata
22. Call data area panel 2
23. Call data area panel 1
24. Configurator access button
25. RTSP camera menu
26. User interface access button

## 4 OPERATING MODES

The operating mode of the switchboard depends on its operating status and whether the switchboard itself is of competence for a device.

Refer to the [IPerCom system installer's technical manual](#) for the definition of competence switchboard for a device.

To change switchboard status, click on related icon  and choose the status:

- Day 
- Night 

The  button, on the other hand, allows you to Logout, lock the device, reboot the system or shut it down.

The corresponding status icon displays the selected status.

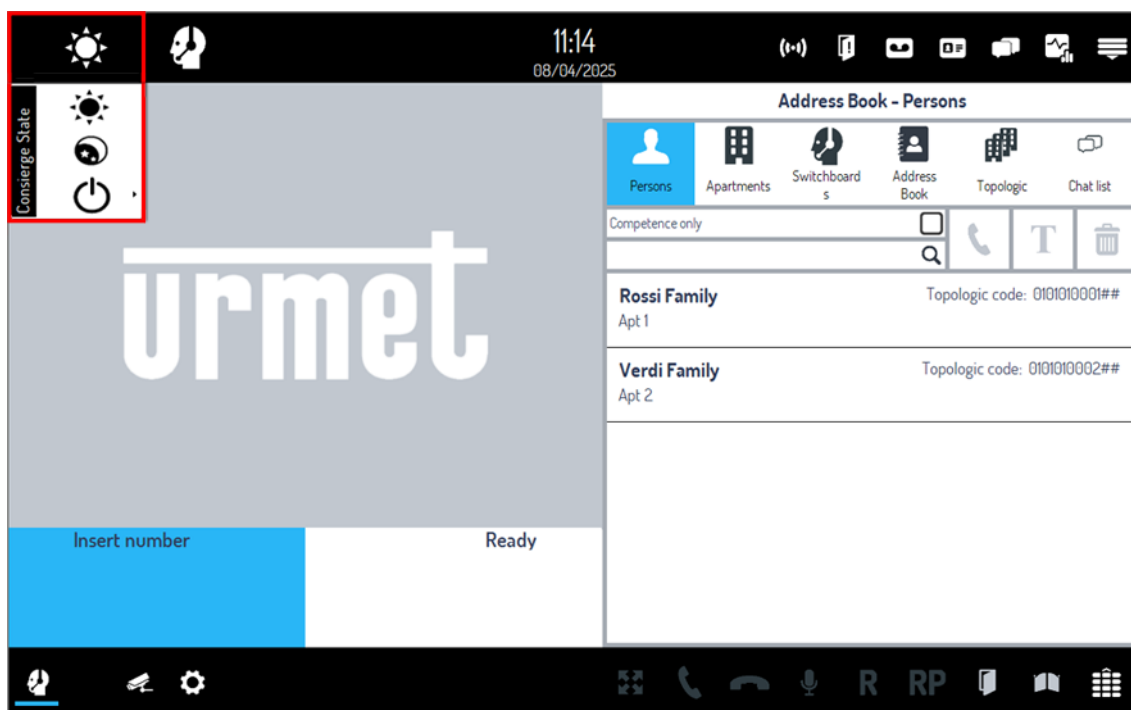

The following describes the possible operating modes of the switchboard in relation to sending and/or receiving calls and the set status.

### 4.1 LOGOUT / DEVICE LOCK / DEVICE RESTART / DEVICE SHUTDOWN

Pressing the  button in the switchboard status display area displays the following functions:

- **Logout:** The session is terminated, the login page is displayed and the switchboard is set in stand-by mode.
- **Device barring:** access to the session is maintained and the login page is displayed. The calls continue to be received and it will be possible to answer lifting the microphone. Once barred, the switchboard maintains the operating status in which it is found (for example, if barred in day or night mode, it will remain in that status). To release the switchboard, you must re-insert the password.
- **Restart the device:** The device is restarted.
- **Stop the device:** The device is off.

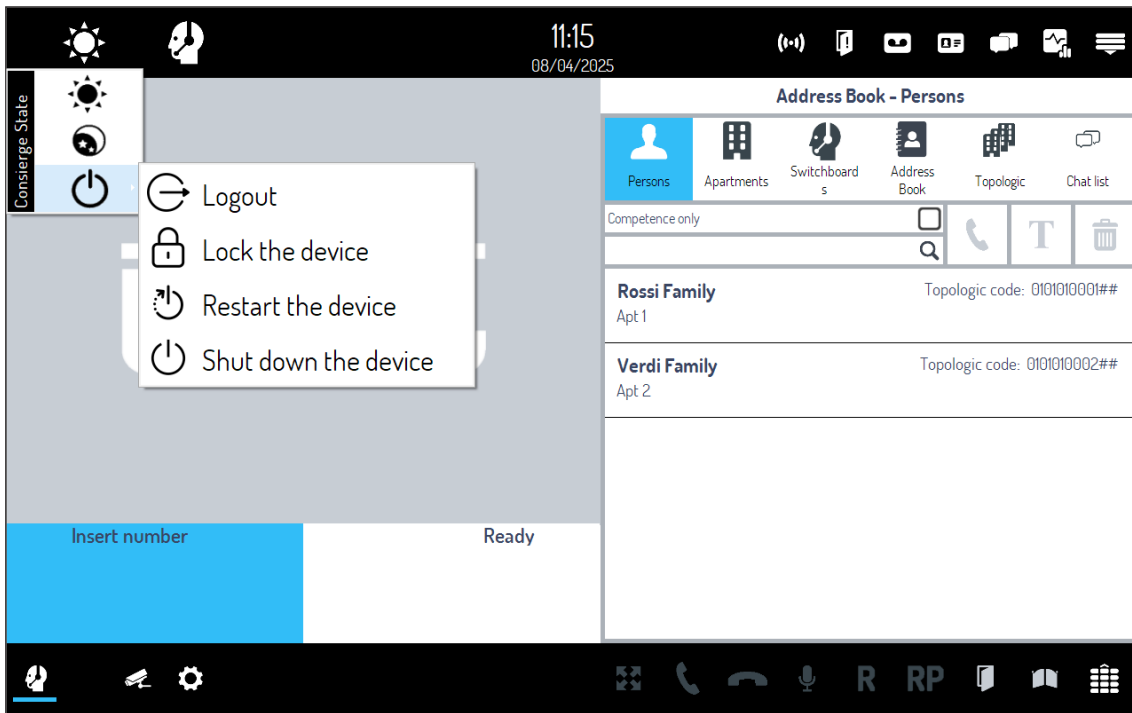

✎ If a switchboard is in stand-by mode, you can divert the calls to another switchboard. For further details, see the paragraph [“Concierge Service Configurations”](#).

✎ The signals for alarm, door open, lost calls, chat messages are disabled in stand-by status. When the switchboard returns to day or night status, alarms or door open alerts (generated when the switchboard was in standby) are then notified.

## 4.2 SWITCHBOARD IN NIGHT MODE

This mode is shown with icon  in switchboard status display area : the concierge service is inhibited and calls from calling stations are sent directly to users. In detail:

- Calls coming from calling stations to apartment stations are directly addressed to users (they are not intercepted by switchboard);
- Direct calls from calling or apartment stations to the switchboard: are sent;
- Calls from switchboard to apartment stations: are sent.

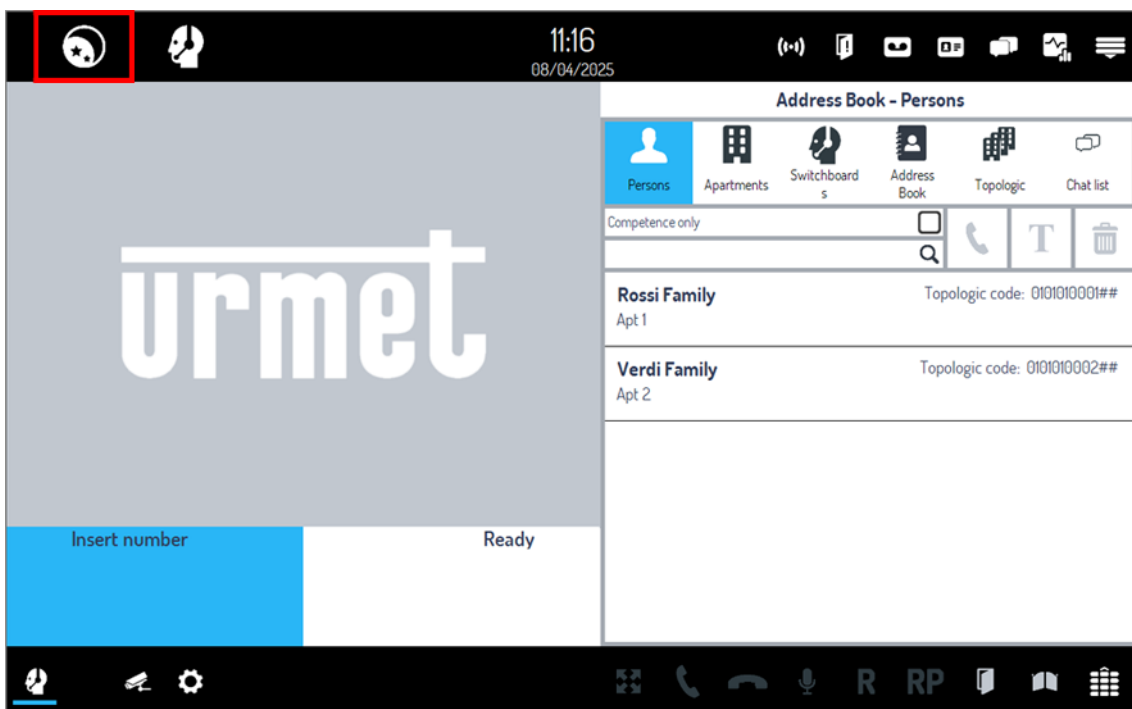

### 4.3 SWITCHBOARD IN DAY MODE

This mode is shown with icon  in switchboard status display area (1). Switchboard application works as concierge service intercepting calls sent from calling stations to users of IPerCom plant. In detail:

- Calls coming from calling stations to apartment stations are intercepted by Switchboard (if this is of competence for apartment stations);
- Calls from apartment or calling stations to the switchboard: are sent;
- Calls from the switchboard to apartment stations: are sent.

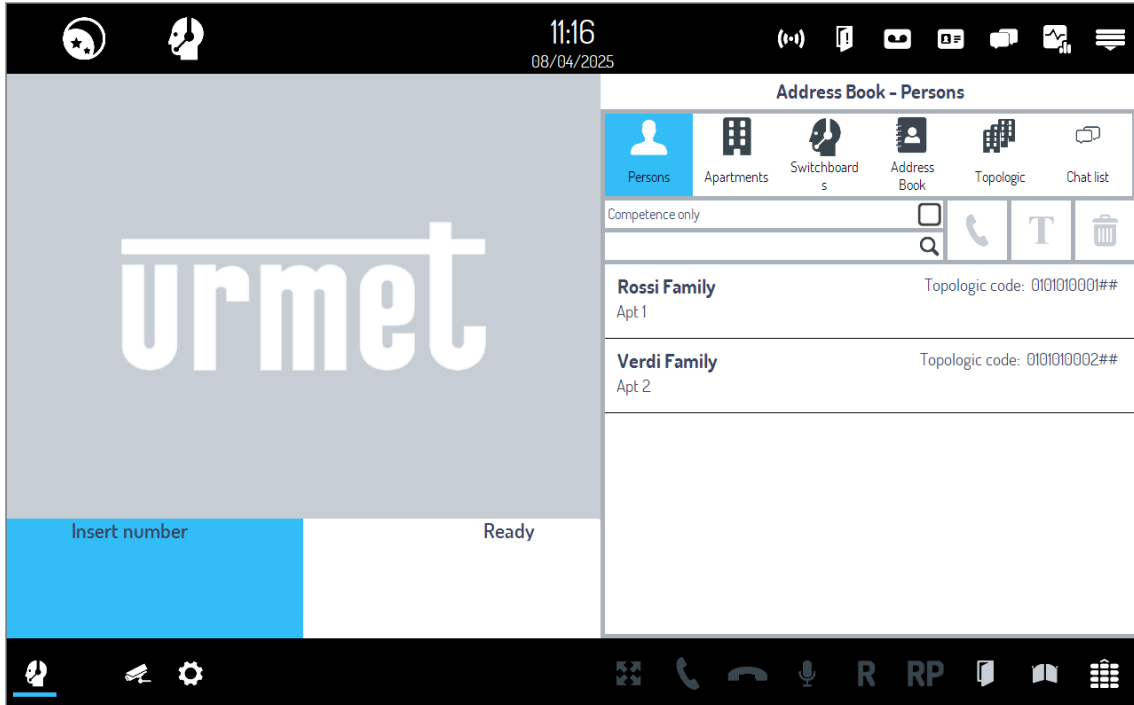
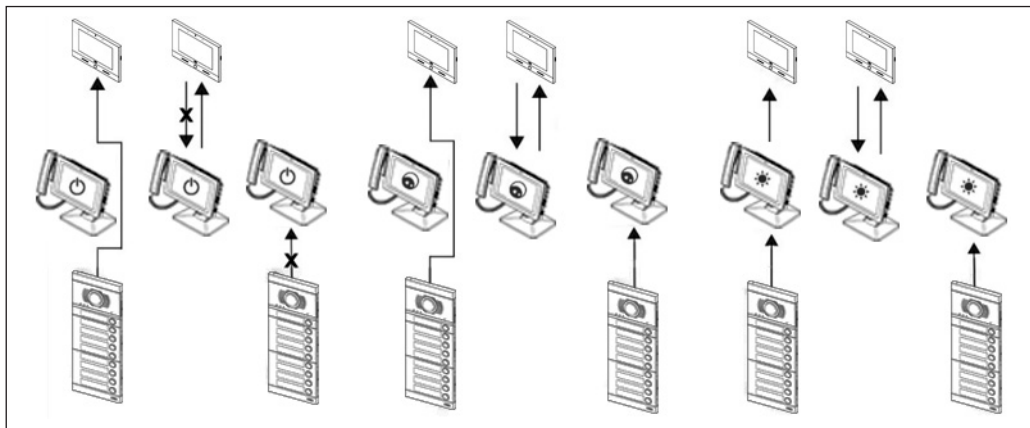
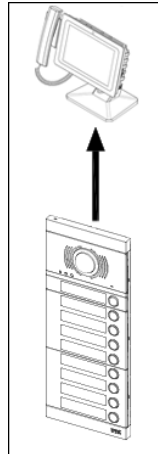

Figure below shows all three operating mode features:



## 5 SWITCHBOARD USE

### 5.1 CALL RECEIVED FROM A CALLING STATION





If a call is sent from a calling station to a switchboard in day or night mode, the following screen is displayed with the following information:



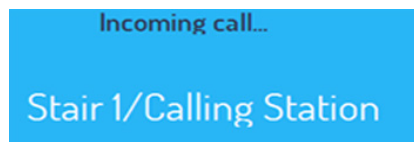

In the call data area panel (red box), the indication appears of the call originator with the name of the door unit preceded by the name of the node where it is positioned. Furthermore, the **Inbound Call** indication is displayed.



In the bottom control bar (green box) the button is enabled to start a conversation  and the button to close the call .







The video picture area shows images coming from calling station camera.

 If the call is directed to several switchboards, a static image is displayed in the video image area; press it (by left-clicking) to display the images taken by the calling station camera. The video stream can be viewed on one switchboard only and no longer on several switchboards at the same time: this means that if a second switchboard (only during the call phase) requests the video stream, this is no longer available to the first one that had already requested it.

You can start audio-video communication with the visitor by lifting the handset or pressing the button to start the conversation  .



Having started a conversation, pressing the following icons you can:

	Zoom or collapse the image displayed		Return to call on hold
	Close call		Open pedestrian door
	Bypass or re-enable the switchboard microphone, to avoid the caller hearing what is said. When the microphone is bypassed, the icon is barred. The icon only appears after answering the call.		Open the driveway

If busy in a conversation, in the case of a new call, the latter is signalled in the call data area panel that remains free.

In this example, the new call was inserted in call data area panel 2.

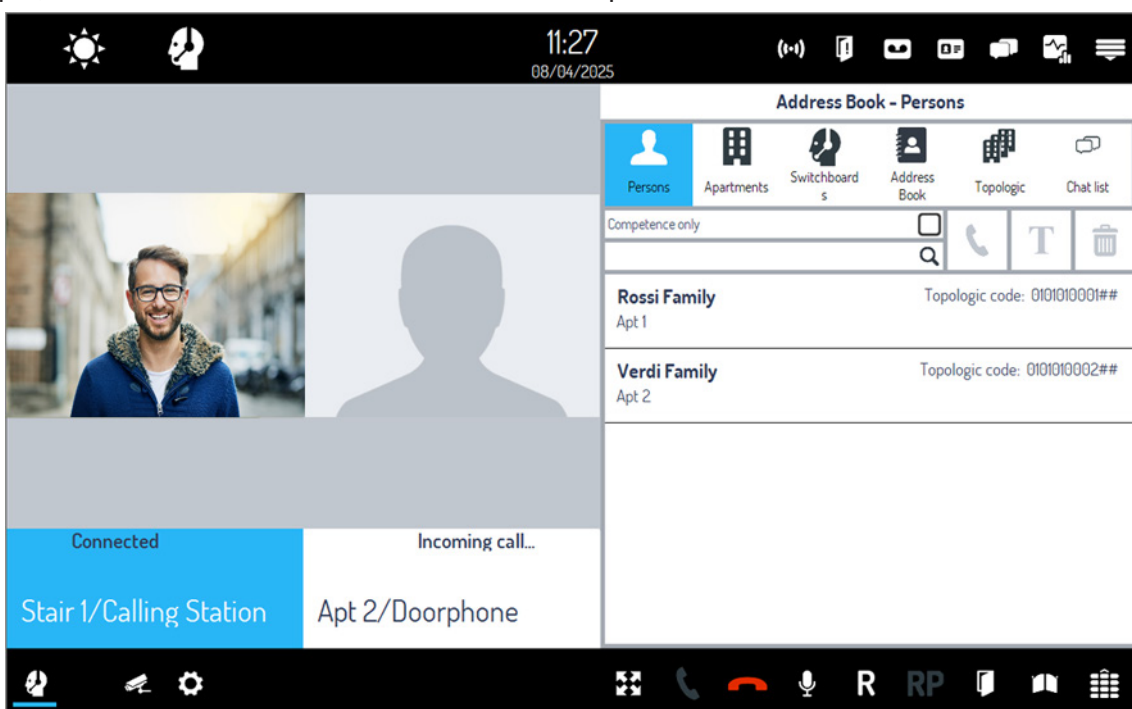

To answer, the call data area panel must be pressed from where the call is coming.

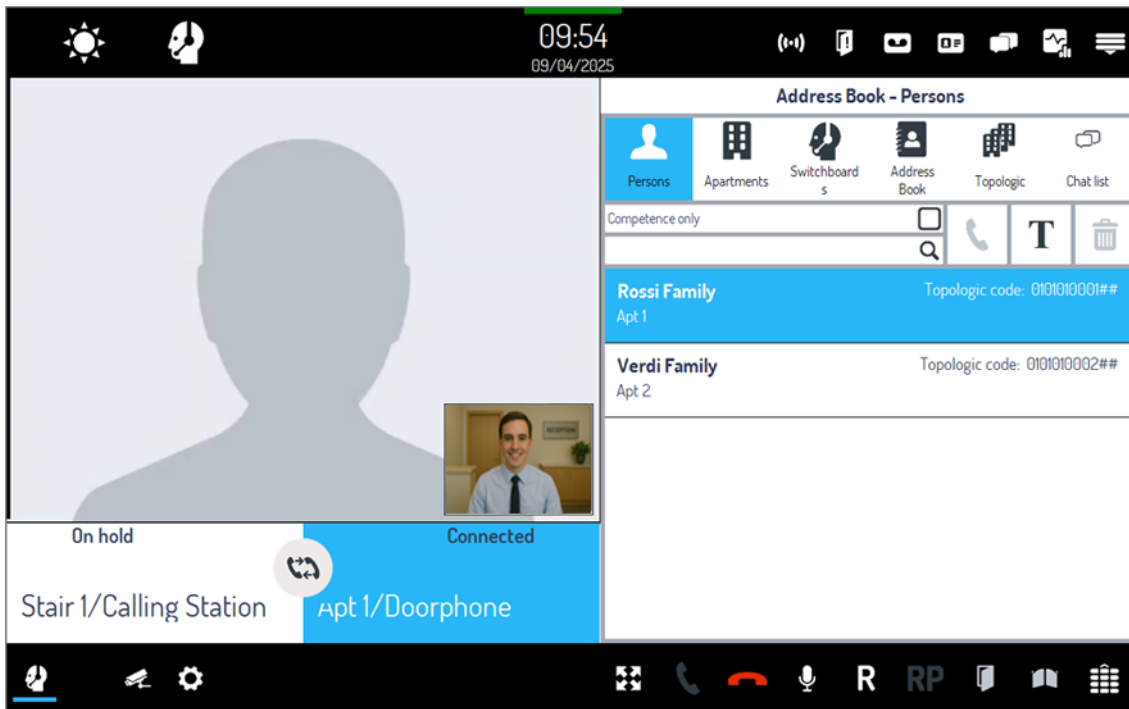

The previous conversation is put on hold (in this example, the call from the calling station).

To close a communication, click on button  (according to the panel on which the call has been received) or hang up handset.

To resume the call on hold, the operator must click on button  after having clicked on the related call data area panel.

 *If both the call panels are busy, the door unit will signal **Busy**.*

 *For all the details on how to call from a calling station the switchboards of a system (of competence or not) see [Ipercom technical manual](#) or the user's and installation manuals of the various calling stations.*

## 5.2 CALL RECEIVED FROM AN APARTMENT STATION

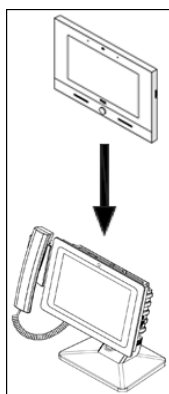

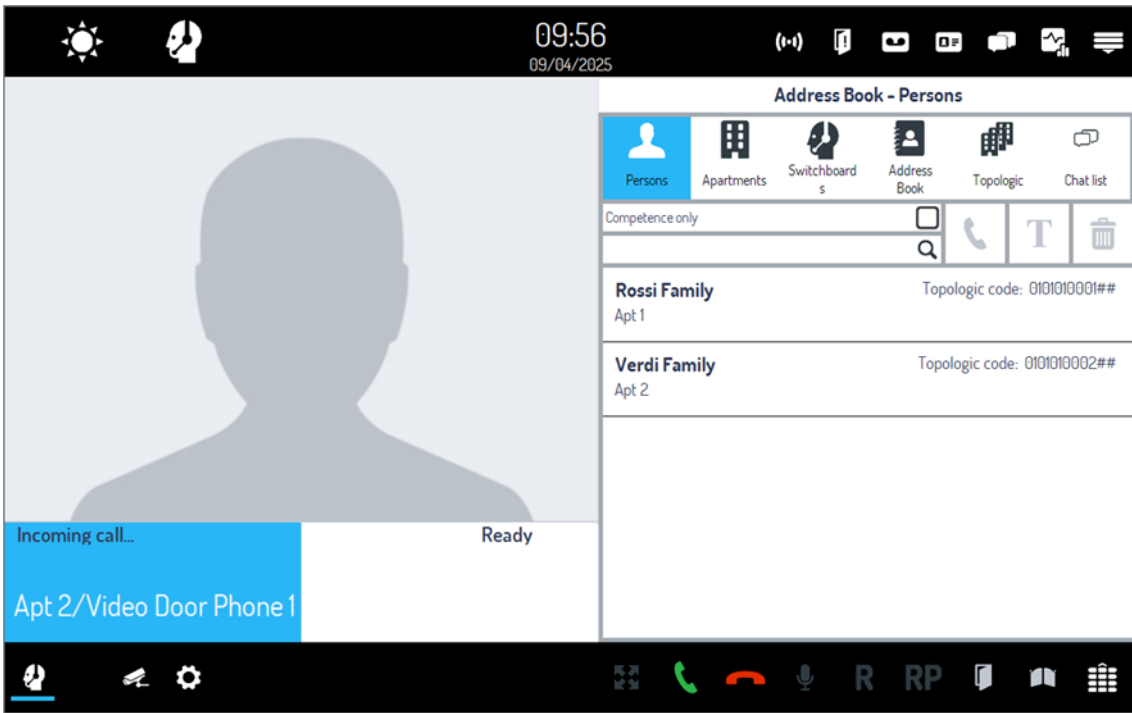

If an apartment station calls the switchboard which is not in stand by mode, Switchboard application shows the following information:

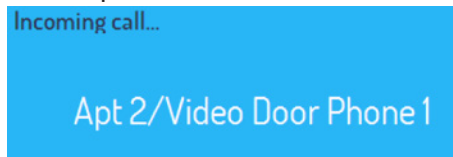

In the call data area panel (red box), the indication appears of the call originator with the name of the indoor set preceded by the name of the node where it is positioned.







In the bottom control bar (green box) the button is enabled to start a conversation  and the button to close the call .

In the video images area (blue box), the call originator's image is not visible until the user that made the call enables the display, if possible.

You can start audio-video communication with the apartment by lifting the handset or pressing the button to start the conversation .



Having started a conversation, pressing the following icons you can:

	Zoom or collapse the image displayed		Bypass or re-enable the switchboard microphone, to avoid the caller hearing what is said. When the microphone is bypassed, the icon is barred. The icon only appears after answering the call.
	Close call		Return to call on hold

If busy in a conversation, in the case of a new call, the latter is signalled in the call data area panel that remains free.

In this example, the new call was inserted in call data area panel 2.

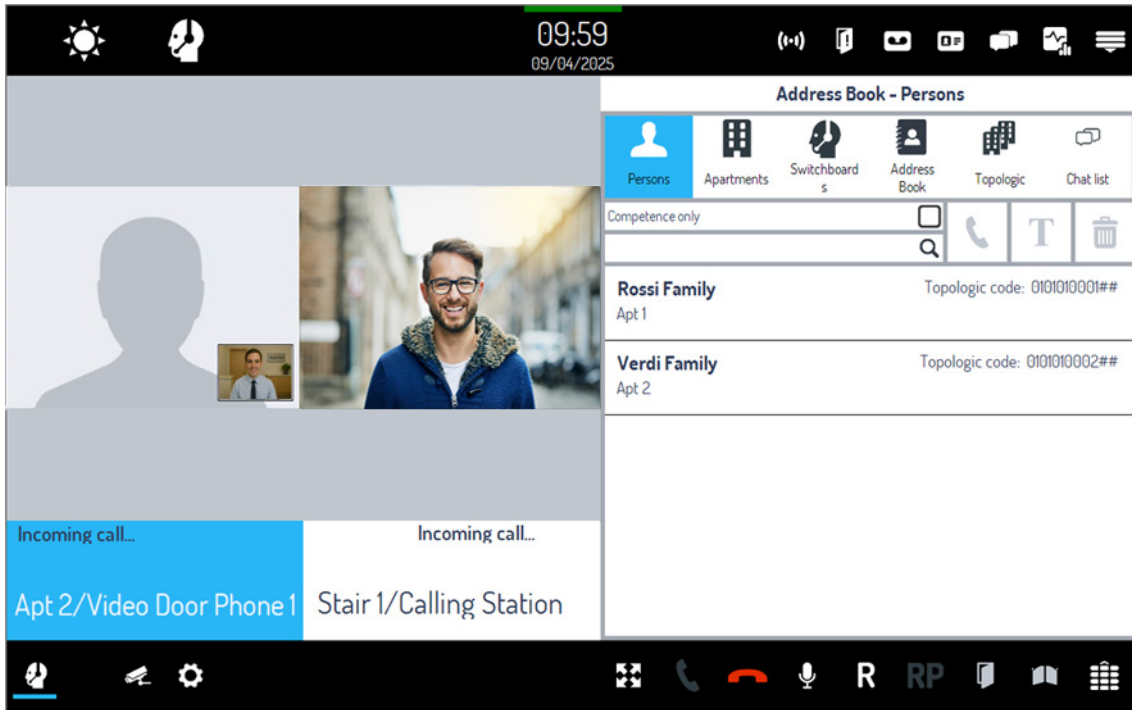

To answer, the call data area panel must be pressed from where the call is coming.

You can only see the image if the call arrives from a calling station.



The previous conversation is put in hold (in this example, the call from the video door phone).

To close a communication, click on the button  (according to the panel on which the call has been received) or hang up handset

To restart the call put on hold, press the button  after selecting the corresponding call data area panel.

 If both call data areas are busy, the apartment station shows *Busy* on its display (if not equipped with display, it emits a deterrence tone).

 For all the details on how to call from an apartment station the switchboards of a system (of competence or not) see [Ipercom technical manual](#) or the user's and installation manuals of the various calling stations.

### 5.3 RECEIVING A CALL FROM A CALLING STATION AND FORWARDING TO A USER (CONCIERGE SERVICE)

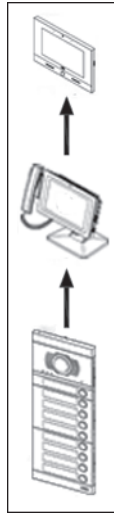



If a call is sent from the door unit to an apartment with a competent switchboard, if it is in day mode, the following screen is displayed with the following indications:

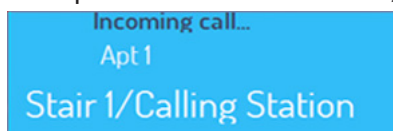

In the call data area panel (red box), the indication appears of the call originator with the name of the door unit preceded by the name of the node where it is positioned. Furthermore, the Inbound Call indication is displayed.









In the bottom control bar (green square) the button is enabled to start a conversation  and the button to close the call .

The video image area (blue box) shows what was taken by the door camera.

You can start audio-video communication with the visitor by lifting the handset or pressing the button to start the conversation .



Having started a conversation, pressing the following icons you can:

	Zoom or collapse the image displayed		Return to call on hold
	Close call		Open pedestrian door
	Bypass or re-enable the switchboard microphone, to avoid the caller hearing what is said. When the microphone is bypassed, the icon is barred. The icon only appears after answering the call.		Open the driveway

Pressing the blinking icon  in the call data area panel, the following functions are displayed.



The button  allows you to call the apartment selected on the door unit.

Having pressed the button, the door unit will be put in standby and the call will be forwarded to the apartment and inserted in the next call data area panel.

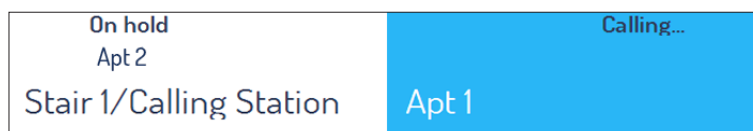



When the user answers from the apartment station, he/she enters in audio or audio-video communication with the switchboard.



In this case, the call data area panel displays the message Connected.

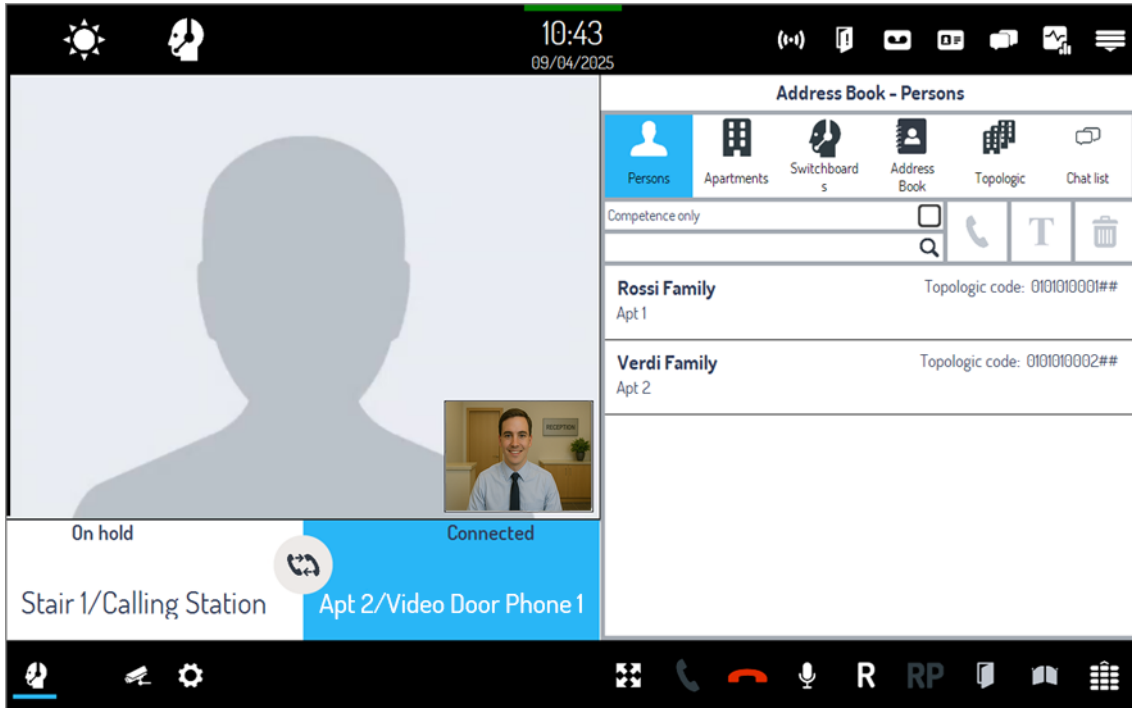

A still image generally appears in the video image area, but in the lower right corner there is a small box with the same video stream that the user sees on the video door phone display.



To connect the calling station to the user, simply press the  button.

The button  can be used to send a chat message to the chosen resident or apartment (the message is sent to all video door phones in the apartment), for example, if the user does not reply or does not want to be disturbed. Once the message has been sent, the button  can be used to close the conversation.

## 5.4 CALL TO A USER WITH CODE

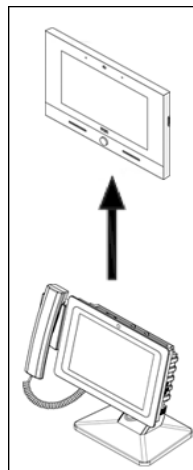

If you know the apartment code (topological, logical or numeric) of the user you intend to call, follow the below: Select one of the two call panels.

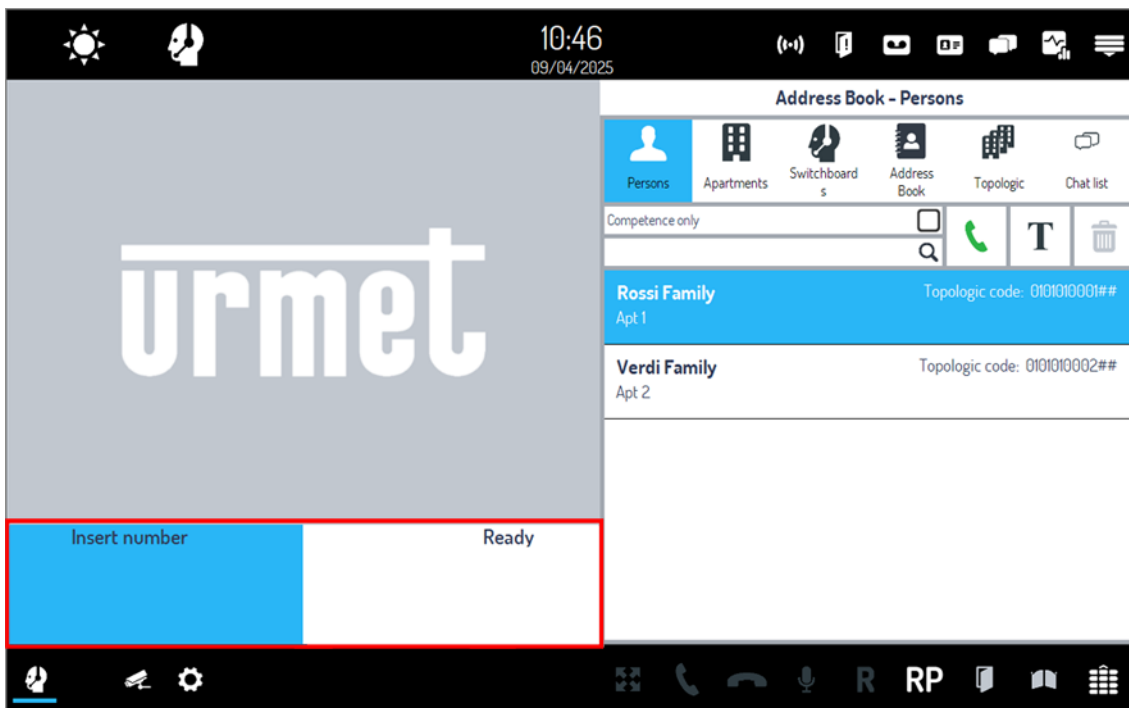

In the bottom control bar, press the button  to show the virtual keypad on the display.

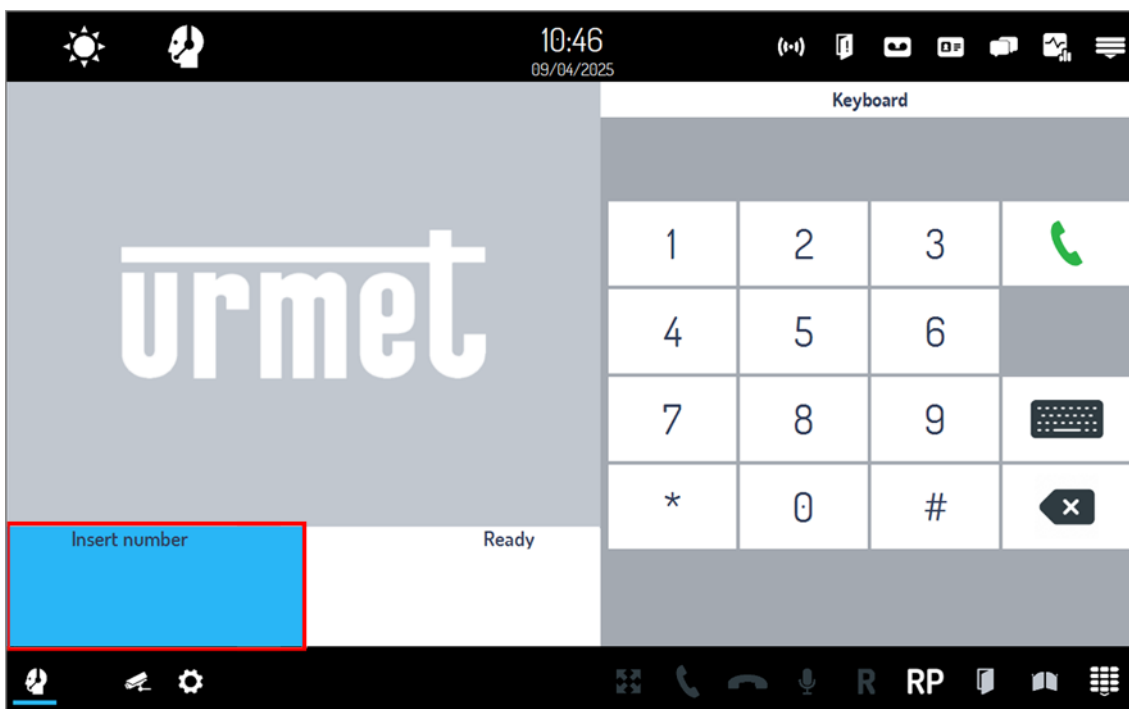

Type the apartment code of the user on the keypad. The typed code appears in the selected call data area panel.

If a wrong character is entered, click on button  to delete the last entered character.

After entering the code click on the button  to start the call.

If there is a wrong code or it doesn't exist in the call data area panel, User not found is indicated.

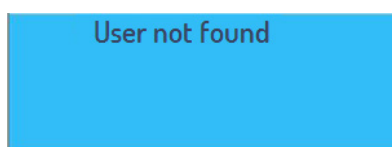

To interrupt a call-in progress, simply press the  button or hang up the handset (depending on the panel on which the call came in);

If the user is busy in another conversation the following indication appears:



If the user is free his extension starts ringing, the moment he answers the call, it enters into audio or audio-video communication with the PBX.

In this case, the call panel displays the words **Connected**.

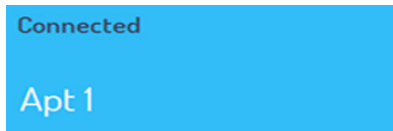

The video image area displays the video stream that the user views on the video door phone display.

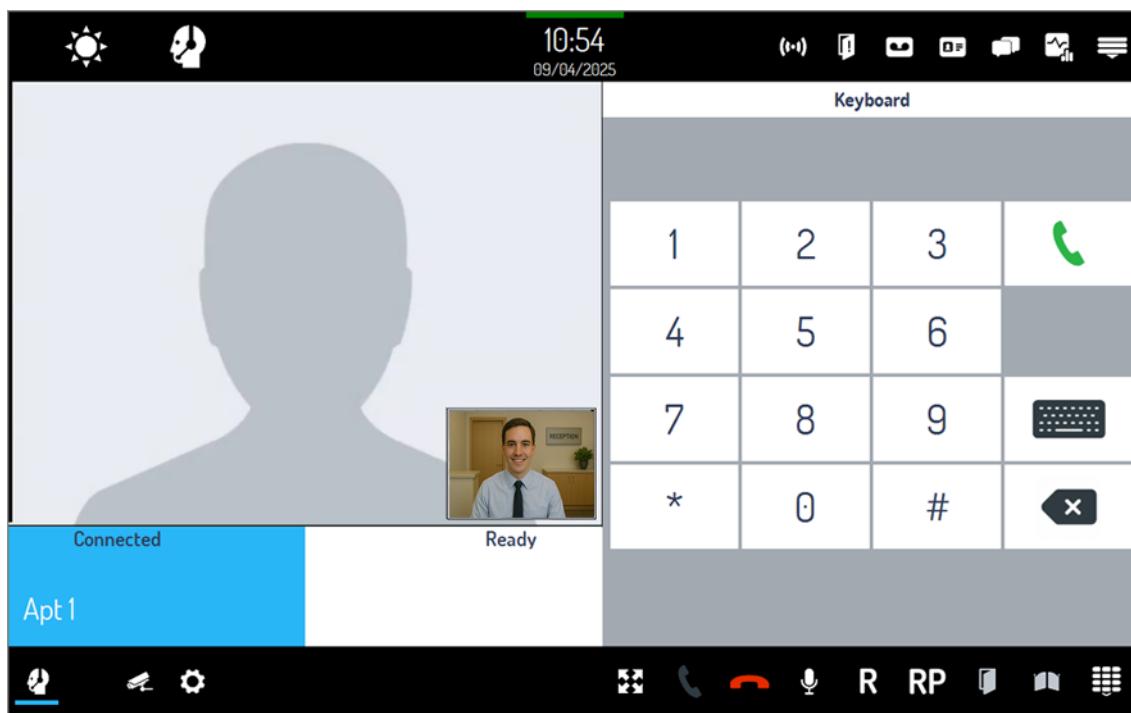

Al termine della comunicazione, il centralino torna nelle condizioni iniziali.

Per ripetere l'ultima chiamata effettuata verso un utente è possibile premere il pulsante **RP**.

*If the indoor set called is a video door phone, the video flow of the switchboard is sent to the video door phone already in the call phase. This only applies if, in the device configuration menu (accessible via the "Configure" button in the "Other options" menu), you have selected the Integrated Webcam parameter under the Camera item.*

*If the video door phone is also equipped with a camera, the switchboard can receive the video stream in the video images area, provided the indoor set enables its transmission during the conversation.*

## 5.5 CALL TO A USER WITH THE ADDRESS BOOK

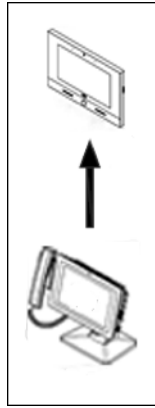

If the user code is unknown, operate as follows:  
Select one of the two call areas.

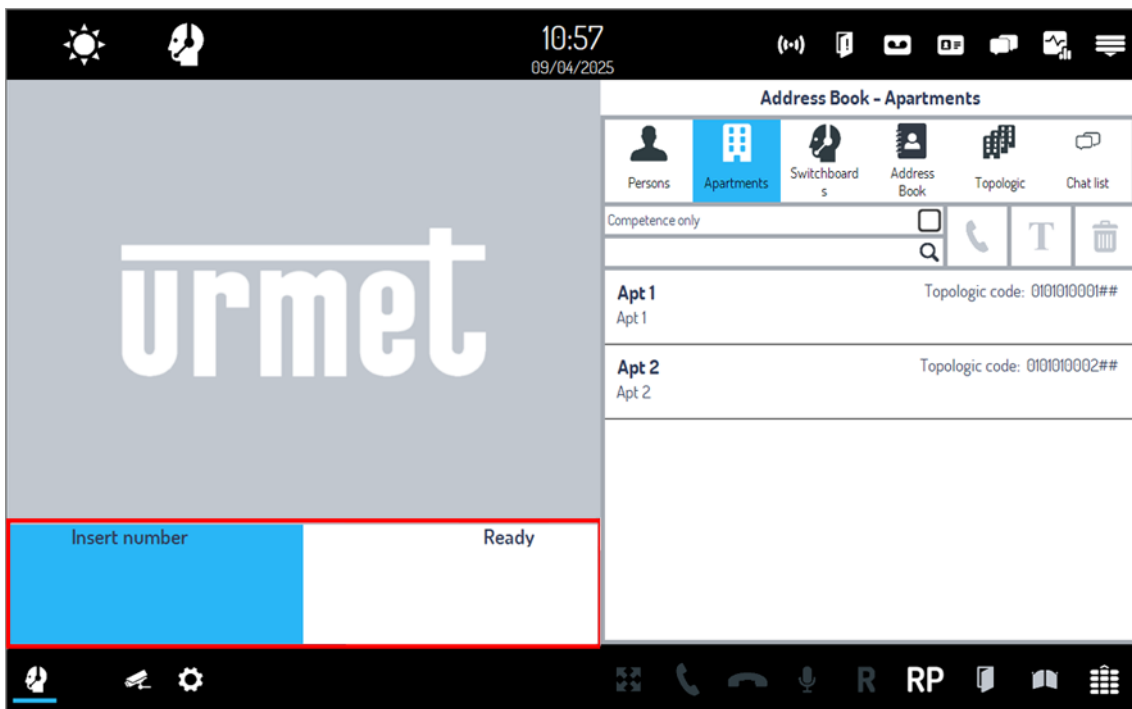

In the top control bar, press the button . In the contextual section on the right, the users address book is displayed.

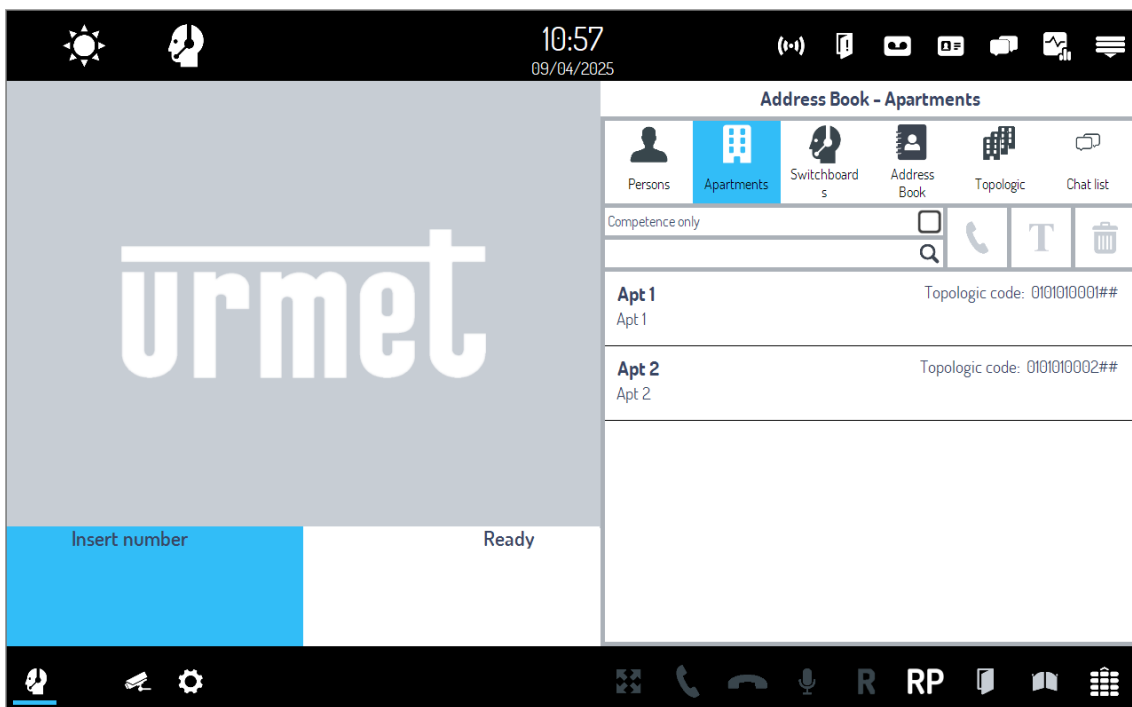

You can search the user to call by name or by apartment. These two search windows will be briefly described before describing how to call a user using the address book and how to send a chat message.



 For the construction of rubrics refer to the [lpercom technical manual ver. 3.2](#).

### 5.5.1 USER SEARCH BY NAME

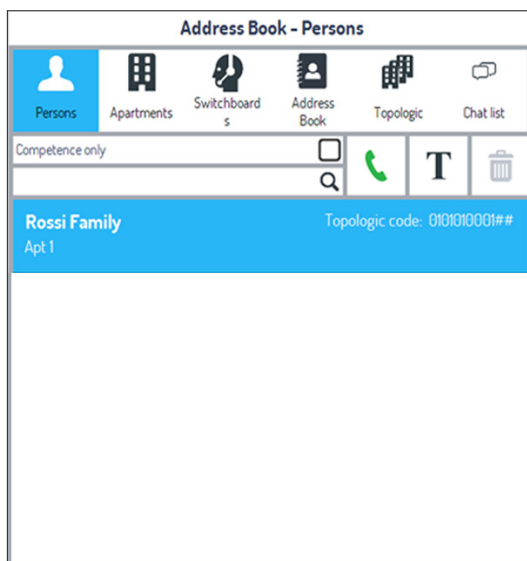
The “Users” tab  (default) displays the following screen:



On the following screen you can:

- displaying name, apartment, calling and topological code of all users of the system;
- calling with button  the selected user (button is enabled when a user has been selected);
- sending a chat message with button  to the selected user (button is enabled when a user has been selected). The button is only enabled if, in the selected apartment, there are indoor sets compatible with the chat function.

 The call to a user calls all video door phones of the apartment of the user; in the same way, a chat message to a user is sent to all video door phones of the apartment of the user.



The item “Competence only”, if selected, allows reducing address book only to the users that are of competence of switchboard (this item also affects the “Apartments” tab).

To quickly search a user to call, simply write in the white box, containing the icon , the user’s name or a part; by doing so, only the users will be displayed who contain the characters entered. The same applies for the “Apartments”, “Switchboards” and “Address book” tabs which will be described below.

## 5.5.2 USER SEARCH BY APARTMENT

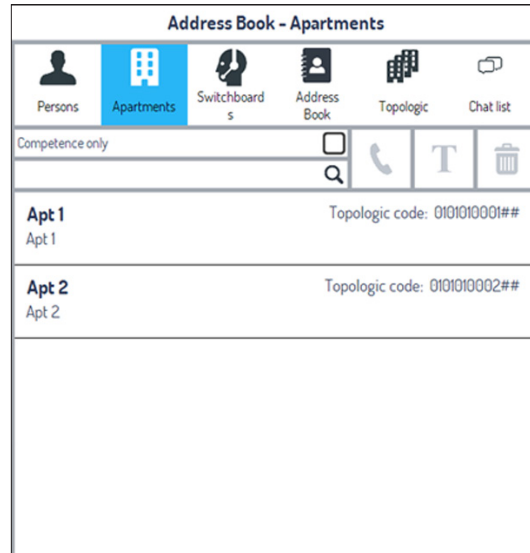
“Apartments” tab  allows:



- displaying name, calling and topological code of all apartments of the system;
- calling with button  the selected apartment (button is enabled when an apartment has been selected);
- sending a chat message with button  to the selected apartment (button is enabled when an apartment has been selected). The button is only enabled if, in the selected apartment, there are indoor sets compatible with the chat function.

 *The call to an apartment calls all video door phones of the apartment; in the same way, a chat message to an apartment is sent to all video door phones of the apartment.*

## 5.5.3 CALL TO A USER BY ADDRESS BOOK

After having chosen the user or apartment or single video door phone to call in one of the two modes explained above, click on button  in the related window;

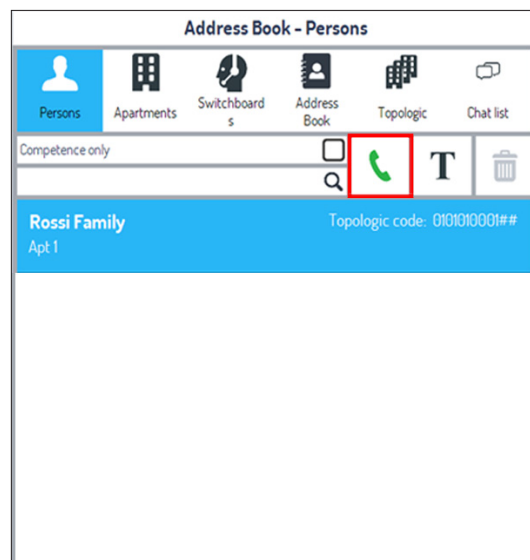

The name of the called apartment appears in the call panel area with an indication that the call is in progress:



Se l'utente è libero il suo interno inizia a squillare mentre se è occupato in un'altra conversazione compare la seguente indicazione:



Before answering, the user will see on the display the image taken by the switchboard webcam, provided the **Integrated Webcam** parameter has been selected as a video output device in the “**Other options**” menu.

At the end of the communication, when the operator hangs up the handset or presses the  button, the switchboard returns to its initial condition.

To repeat the last call made to a user you can press the button **RP**.

#### 5.5.4 SENDING CHAT MESSAGE

After having chosen the user to call in the tab “Persons” or the apartment to call in the tab “Apartments”, the button **T** allows sending a chat message to the selected user or apartment: in both cases chat message is dispatched to all video door phones of the apartment.

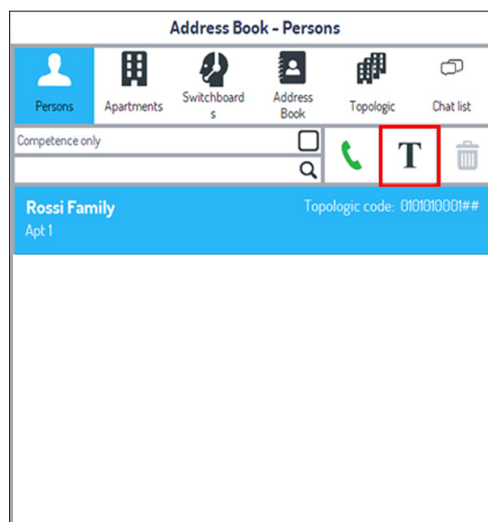

The following window appears:

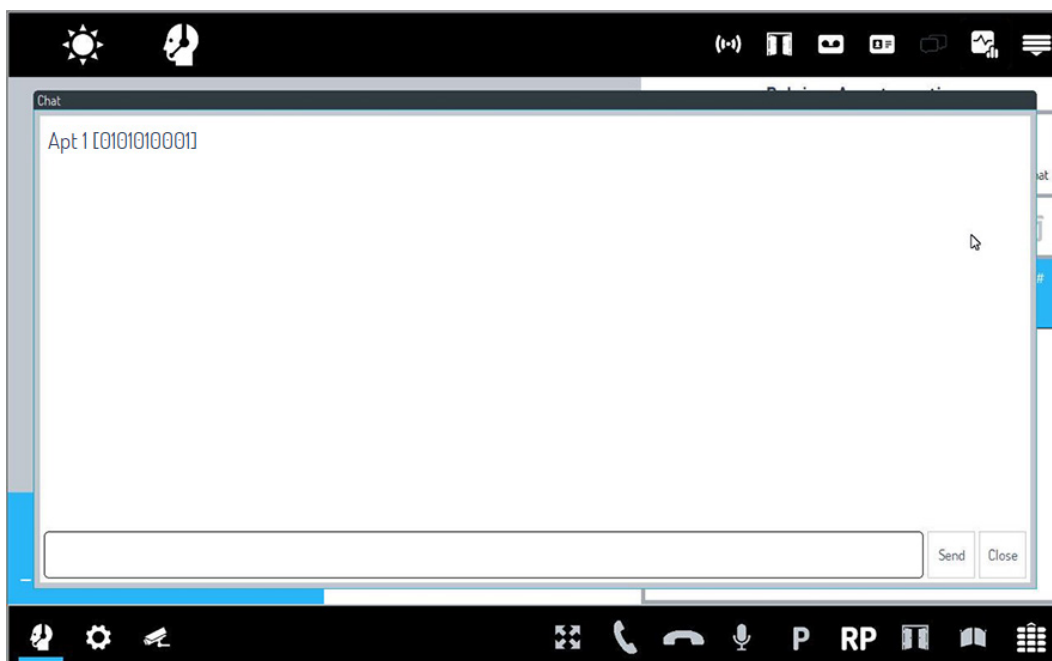



Simply write the message in the box and press the **Send** button.  
To close the screen without sending a message, press the **Close** button.

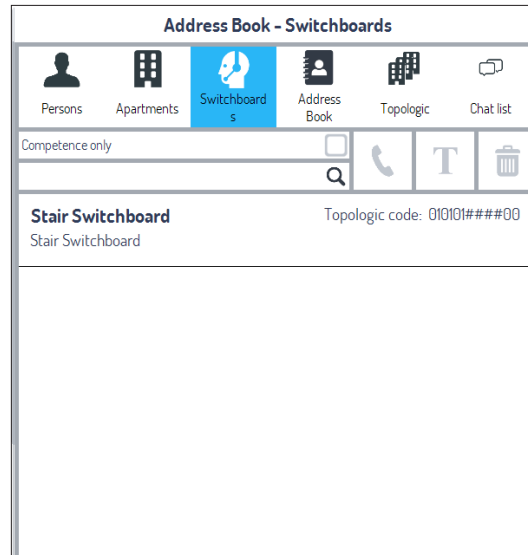

### 5.5.5 SWITCHBOARD SEARCH

“Switchboards” tab  allows:



On the following screen you can:

- displaying name and topological code of all switchboards of the system;
- calling with button  the selected switchboard (the button is enabled when a switchboard is selected);
- sending a chat message with button  to the selected switchboard (the button is enabled when a switchboard is selected).



The buttons  and  work in the same way as described in the previous chapter.

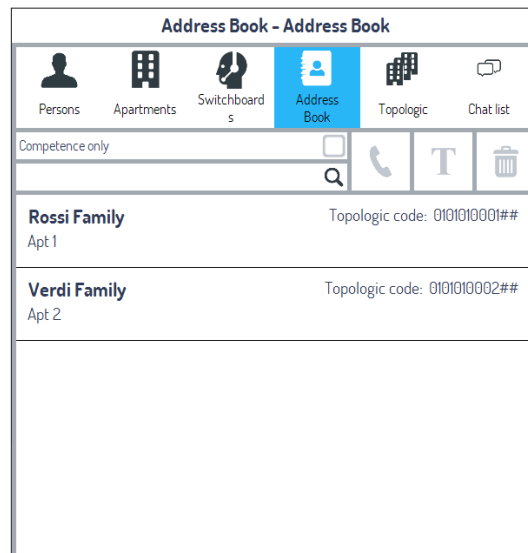

### 5.5.6 CONTACT SEARCH

The “Address Book” tab  displays the following screen:



On the following screen you can:

- displaying name and topological code of all contacts added in address books (for further information see [Ipercom technical manual ver. 3.2](#));
- calling with button  the selected contact (the button is enabled when a contact is selected);;
- sending a chat message with button  to the selected contact (the button is enabled when a contact is selected)..

Buttons  and  work in the same way described above.

 Under the name of the contact, it is also indicated whether a single apartment station or all the apartment stations of the node are called.



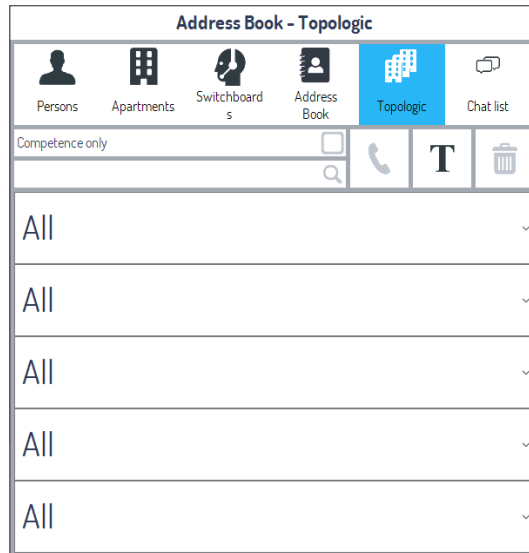

 Contacts of the “Calling stations” are not displayed.

### 5.5.7 SEARCH BY TOPOLOGICAL CODE

The “Topological” tab  displays the following screen:



On the following screen you can:

- press on the different topological nodes, to select the topological structure of the plant.
- call with the button  the apartment or device belonging to the selected apartment in the previously selected topological node.
- send a chat message with the  button to entire topological sections, such as an entire staircase or even to a single device,
- buttons  and  function in the same way as described above.

### 5.5.8 CHAT LIST

“Chat list” tab  allows displaying the list of all active chats with switchboard:

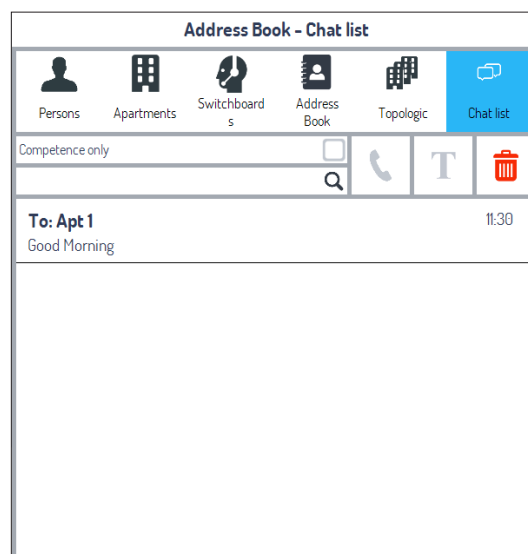

The video door phone **VOG+ Ref. 1761/6**, the **Miro Ref. 1160/3** and the apartments **IperTalk** and **Ipercloud** cannot receive any chat message.

Selecting a single chat, the button **T** is enabled: clicking on this button, it is possible to continue the chat in progress.

Selecting a chat with a video door phone or with an apartment, button  is enabled: it is possible to make a call to the video door phone or to the apartment.

The  button allows you to select the chats you wish to delete.

Select the chat and press the button  to eliminate it.

The button  allows you to return to the previous screen without eliminating the chat.

## 5.6 RECEIVING A CALL FROM A USER AND FORWARDING IT TO ANOTHER USER



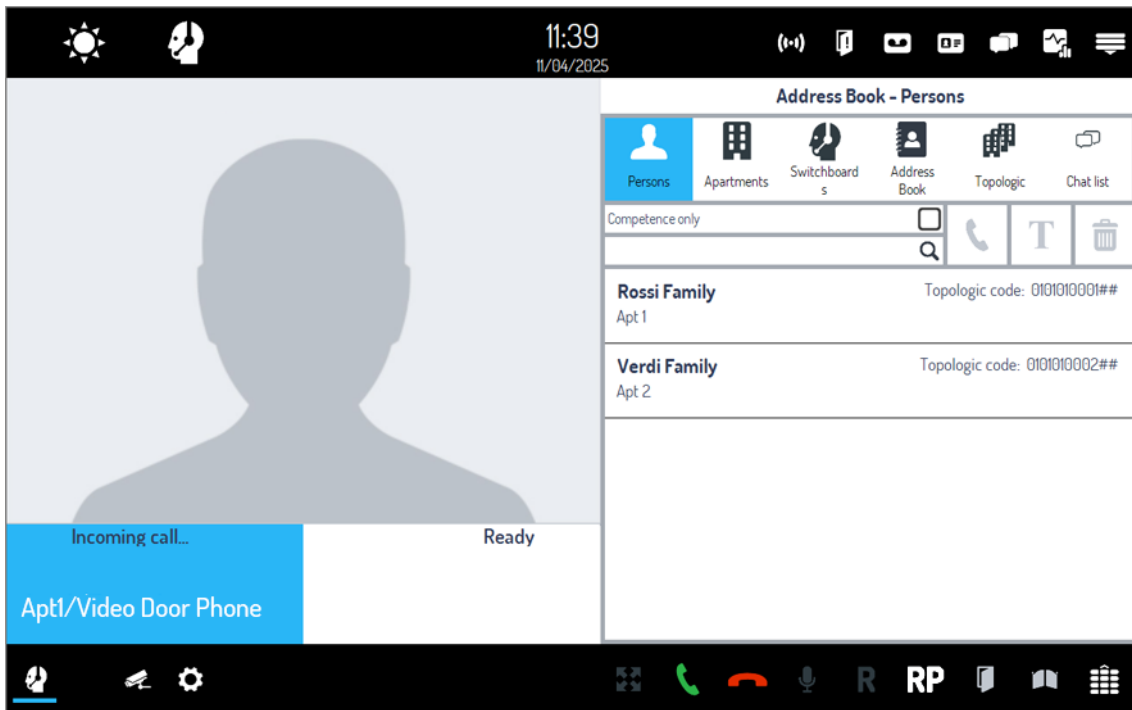

If an apartment user makes a call to the switchboard and the switchboard is not in a stand-by state, the following screen is displayed:

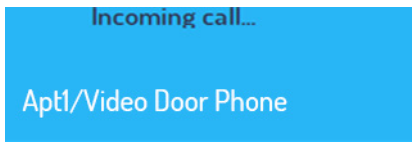

In the call data area panel the indication appears of the call originator (name of indoor set preceded by the name of the node where it is positioned).



In the bottom control bar the button is enabled to start a conversation  and the button to close the call .

In the video images area, the image of the call originator is not visible until the user who made the call has enabled the display (if supported by the indoor set).

Lift the handset or press the button  to start a conversation with the user.





To forward the call to a second user of the switchboard, the operator must:

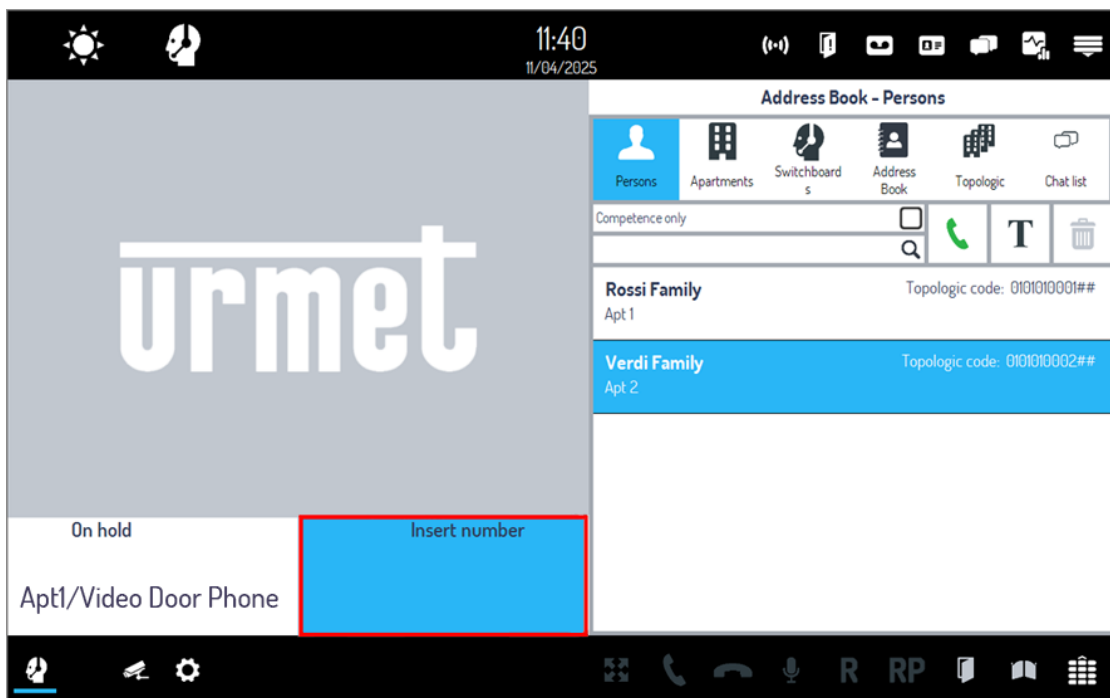

- Select the free call data area panel.

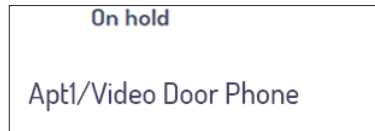

- At this stage the calling user will be placed on hold:



- Press the button  to show the digital keypad, type the code of the desired user and press  to start the call.

Or press the button  to open an Address Book and select the name from those available (see the Address Books paragraph and call to a user with selection from address book). Lastly, press the button  to start the call.

When the user answers from his/her apartment station, he/she enters in audio or audio-video communication with the switchboard.

In this case, the call data area panel displays the message **Connected** and in the video images area the video flow appears of the user displayed on the video door phone display:



To connect the two users with each other, simply press the  button.

## 5.7 RECEIVING A CALL FROM AN OUTDOOR OR APARTMENT STATION AND FORWARDING IT TO ANOTHER SWITCHBOARD

If a call is made from the door unit to the switchboard, in day or night status, the display will show the following screen:



On the call data area panel, the indication appears of the call originator with the name of the door unit preceded by the name of the node where it is positioned. Furthermore, the blinking **Inbound Call** indication is displayed.

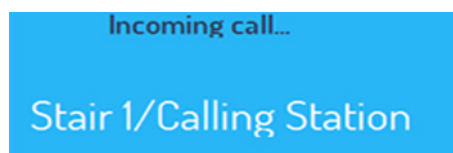

In the bottom control bar the button is enabled to start a conversation  and the button to close the call .

The video image area will show the images recorded by the calling station camera

You can start audio-video communication with the visitor by lifting the handset or pressing the button to start the conversation .



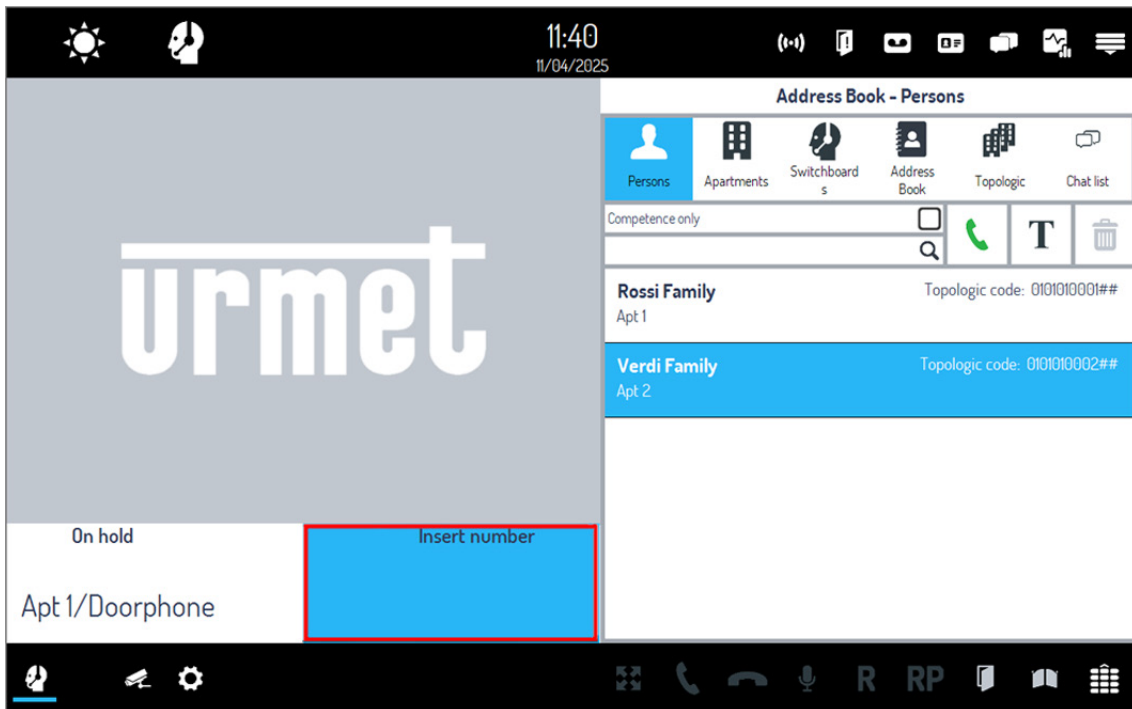

To forward the call to a second switchboard, the operator of the first switchboard must:

- Select the free call data area panel.

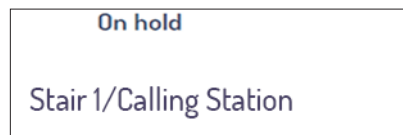

- At this phase the calling station is put on hold:



- Press on the Address Book button  (in case no address book is displayed in the context section) and press on the Switchboard button  (see section [Switchboard search](#)).



- select the switchboard to call.



- Press the button  to start the call with the other switchboard.
- When the operator of the second switchboard answers the call, he/she enters in audio or audio-video communication with the first operator.

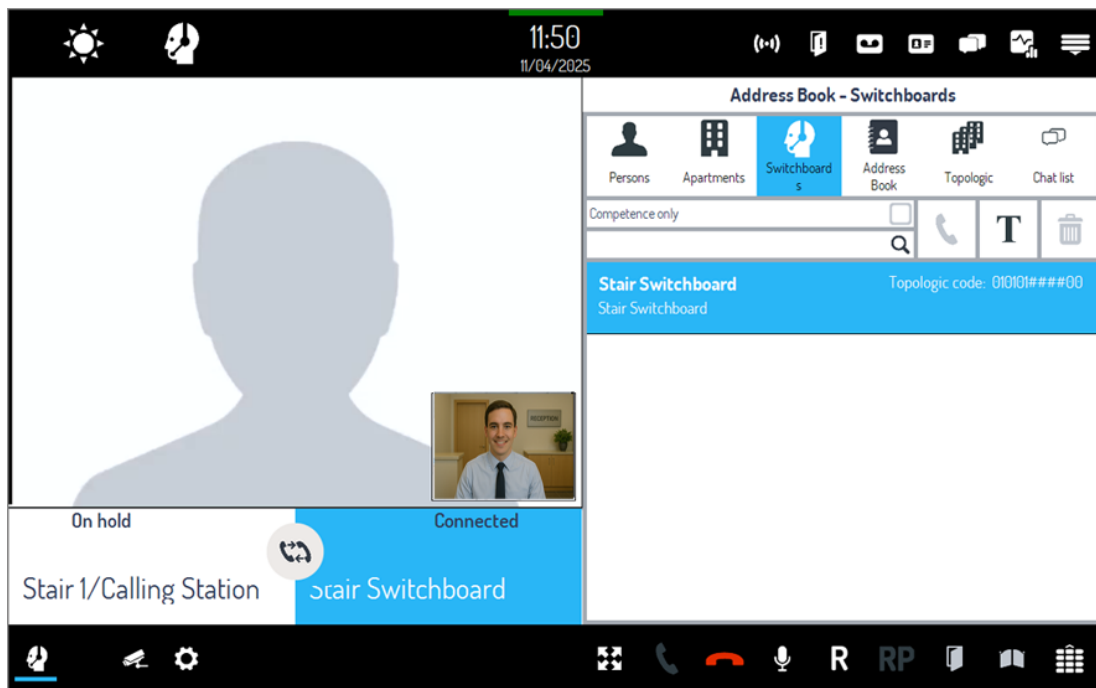

The call data area (8) shows the message **Connected** and the video image area (3) shows either a still image or the video stream coming from the second switchboard (if equipped with webcam).







To connect the calling station to the second switchboard, press the  button (on the Switchboard application of the first operator).

The above is also valid if the call comes from an apartment station: the operator who answers can connect the apartment station to a second switchboard.

## 5.8 TOP CONTROL BAR

The top control bar has the following video door phone functions:



- Alarms 
- Doors open 
- Calls memory 
- Address Book 
- Chat List 
- Diagnostics 
- Other options 

The icons of the functions blink when a notification is received associated with the same function (except the **Other options** and **Address Book** function).

The functions listed above are described in detail below.

### 5.8.1 ALARMS

The system allows sending to the Switchboard the following alarm signals (optical and acoustic):

- **panic** (alarm coming from video door phones or door phones),
- **coercion** (alarm coming from Call Modules or Modular calling station with 1060/48 with numeric keypad),
- **door forced** (alarm coming from Call Modules, Modular calling station with 1060/48, Entry Panels and Key Readers),
- **tamper** (alarm coming from Call Modules and Key Readers)

When an alarm is received, the switchboard beeps repeatedly and the Alarms icon starts flashing red .



It is possible to send alarm signals to the switchboard via events linked to the inputs of the Relay Actuators 1060/84 with firmware version 3.04. The signal is sent when a sensor connected to the input of a Relay Actuator generates the programmed event. The alarms can be of different types (e.g. fire, gas, flood) according to the connected sensor (see [lpercom technical manual \(ver. 3.2 or higher\)](#) for more details).

All warnings can be displayed clicking on item “Alarms” from the menu “View” or clicking on related button  which flashes red in presence of active alarms.

The following figure shows two examples of panic alarm and forced door displays:

The “**Active**” tab displays the active alarms (not yet reset) on the plant, in detail the type of alarm and the source that generated it.

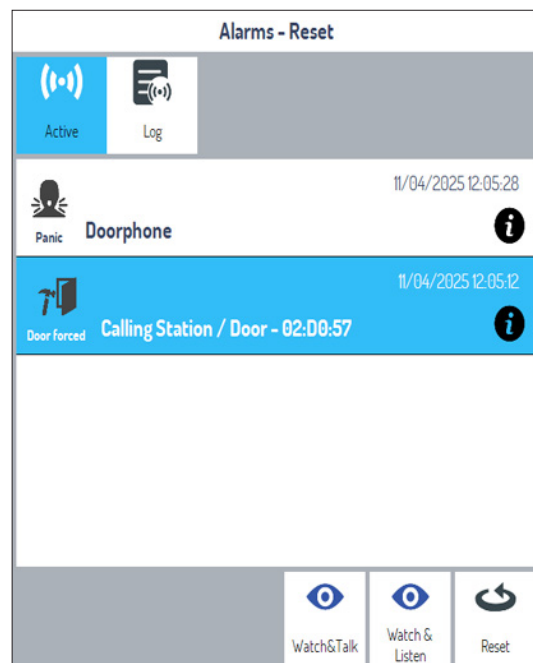
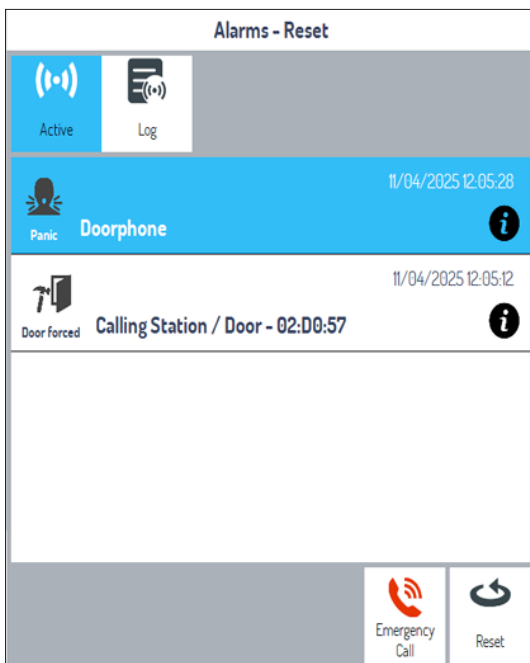

In funzione dell’allarme selezionato vengono visualizzati i seguenti comandi:

<b>Emergency Call</b>	Activation of two-way communication between switchboard and apartment station from which a panic alarm has been received.
<b>Watch&amp;Talk / Watch&amp;List</b>	Activation of auto-on (with monodirectional or bidirectional audio) on: -) Call Module 1060/12-13-17-18-23 for tamper alarm, coercion alarm or door forced; -) Modular panel with 1060/48 for coercion alarm or door forced; -) Entry Panel 1060/71-74-75-78 and Entry Panel 1060/21-33-34 for door forced.
<b>Reset</b>	Delete the selected alarm. The command is active for each type of alarm. The switchboard terminates the alarm acoustic signal.

The “Log” tab shows the following information (for any alarm):

- date and time when the alarm was received,
- date and time when the alarm was reset.

An example of a log related to a received and reset panic alarm is given below:

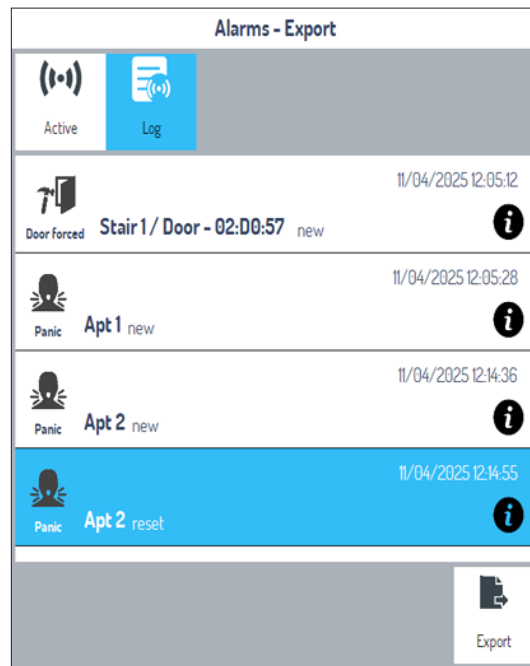



The “Export” button can be used to export the alarm history in csv format (this function is useful if there are many received and reset alarms).

Export is possible only if a USB flash drive is connected to the PBX: in that case, the data are saved in a specific directory automatically created within the flash drive. If no USB device is detected, a popup appears in the lower right corner warning of no removable disks.

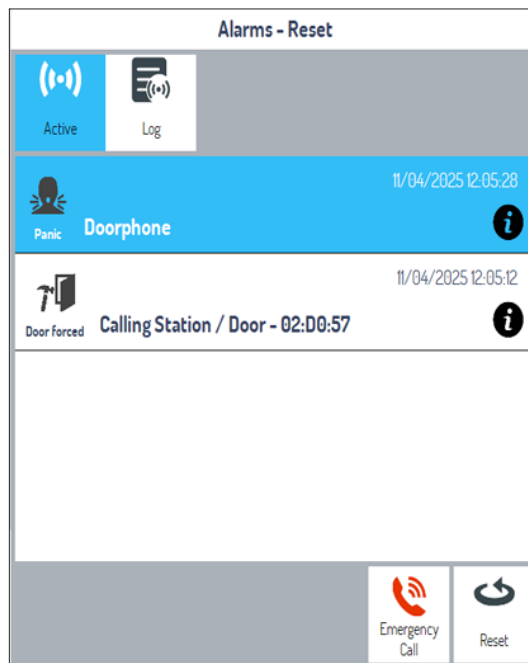

### **PANIC ALARM MANAGEMENT WITH MORE THAN ONE SWITCHBOARD**

If more than one switchboard is present in the system, panic alarm signal will be dispatched to all switchboards of the system. The first switchboard, which activates emergency call, takes charge the received alarm, automatically causing the acoustic signal to be silenced locally and on the other switchboards. The “take of charge” of the alarm is displayed on all switchboards in the related alarm window:



In addition, on switchboards which did not take charge of the alarm, the colour of the icon  turns from red to yellow .

A possible operation of reset from a switchboard (with or without call emergency) causes panic alarm reset on all other switchboards.

-  Taking charge of the alarm can switch from one switchboard to another if the alarm itself is not reset and if the emergency call is closed.
-  The alarm log also shows which switchboard took charge of an alarm and when this happened.
-  Call emergency activation on a switchboard disables receiving and sending calls for all the time during which emergency call is active.

### 5.8.2 OPENED DOORS

For devices to which a door sensor can be connected, the switchboard can display its status. This is valid for pedestrian inputs on the *Call Form 1060/12-13-17-18-23*, *Outdoor Place 1060/71-74-75-78*, *Outdoor Place 1060/21-33-34*, *Modular Hand Control Panel with 1060/48 e Key Reader*.

Press on the relevant icon  to view the list of ports that are left open:

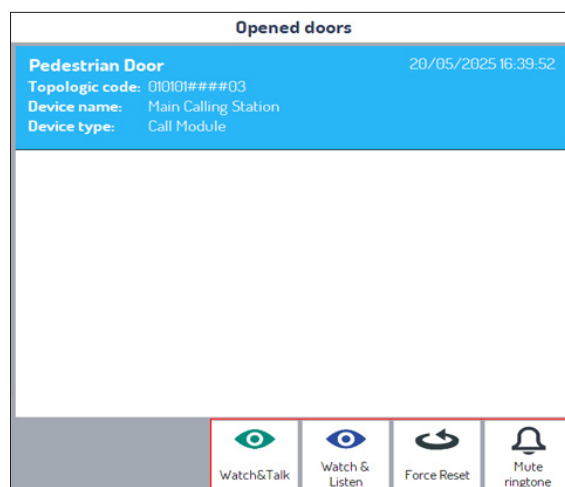

Each time a door remains open, the icon in question blinks and the application can also play an audio file (wav format) previously selected via the **Melodies** item in the Other options menu (see the relevant [Melodies](#) paragraph).

The following operations can be carried out for each open-door signalling using the relevant buttons (highlighted in the red box):

<b>Watch and listen</b>	Allows one-way auto-on on Call Module 1060/12-13-17-18-23, Entry Panel 1060/71-74-75-78, Entry Panel 1060/21-33-34, Modular Entry Panel with 1060/48 whose door has remained open.
<b>Watch and talk</b>	Allows one-way auto-on on Call Module 1060/12-13-17-18-23, Entry Panel 1060/71-74-75-78, Entry Panel 1060/21-33-34, Modular Entry Panel with 1060/48 whose door has remained open.
<b>Force Reset</b>	Allows resetting the door left opened signal regardless of whether the relevant sensor has returned to its previous status.
<b>Mute ringer</b>	Allows muting the acoustic signal for every single open-door event for a preset time (15 minutes, 30 minutes, 1 hour, 2 hours, 4 hours, 8 hours, or 24 hours).

If one or more signals have been muted, they can be enabled again at any time by pressing the “**Enable the ringtone again**”  button. In any case, the acoustic signal will restart as soon as the selected mute time has elapsed.

Opened door alarm disappears as soon as related sensor is closed.

 *If there are multiple switchboards in the system, the door open signal is sent to all the switchboards. The signaling disappears from all switchboards as soon as the relevant sensor returns to the “closed” state.*

### 5.8.3 CALLS MEMORY

If the switchboard operator does not answer to a call, this is stored in a list and the icon  starts blinking red.

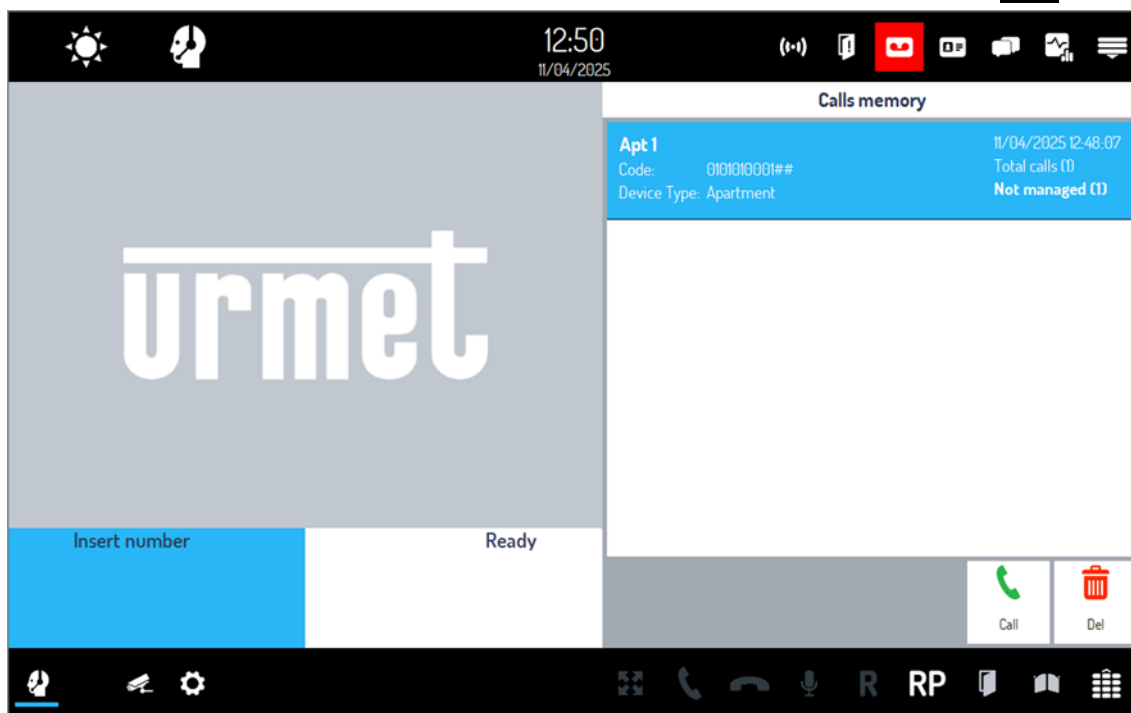

clicking on , icon, the window below is shown where it is possible to view the list of all not answered calls with the name of apartments:

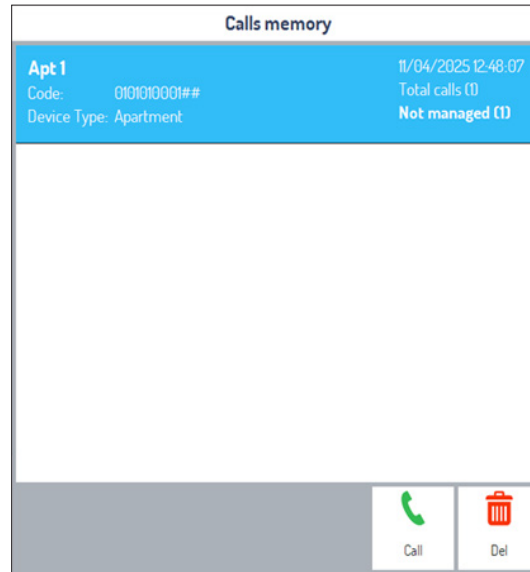

In the lower part of the window the following commands are available:

**Call** Call the selected apartment which received no response

**Del** Delete the selected missed call from the list

The following information is also displayed for each missed call:

- the total number of missed calls (“**Total calls**” field) that the switchboard received from the apartment;
- the number of unmanaged calls (“**Not managed**” field): this number follows the number of missed calls, it is reset as soon as a conversation is established between the switchboard and the apartment in question, it increases again in the presence of new missed calls.

For example, if an apartment called the switchboard 3 times without ever receiving an answer (and without ever having called it before), the following occurs:

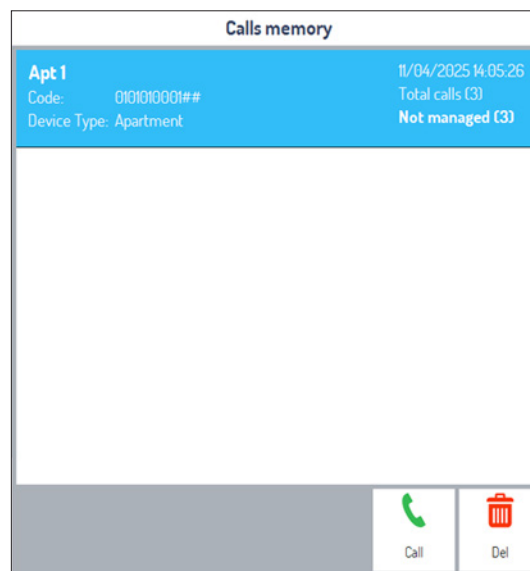

If the switchboard calls the concerned apartment and it answers the call, the “**Not managed**” counter is reset.

The following page opens:

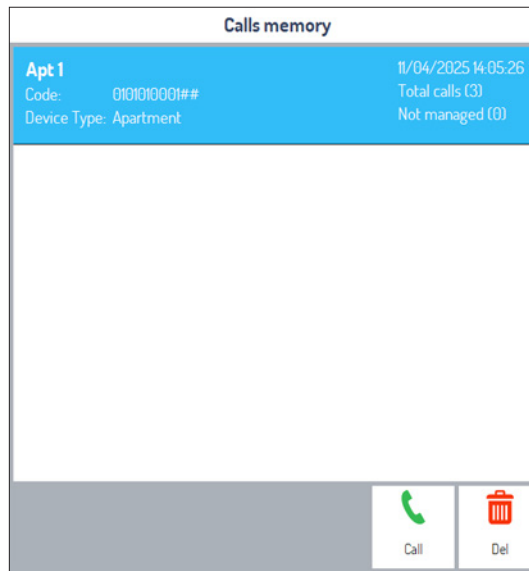

If the apartment calls back the switchboard once again without an answer, the following page appears:

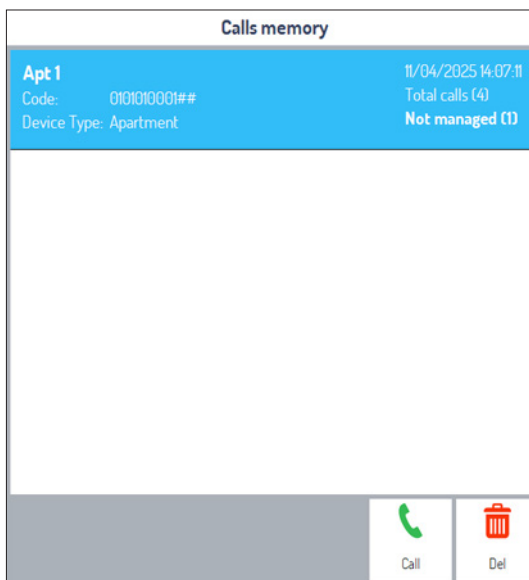

 *Calls from calling stations are not stored in this list.*

### MANAGEMENT OF MISSED CALLS IN PRESENCE OF SEVERAL SWITCHBOARDS

If there are multiple switchboards in a plant, the management of the list of missed calls is “centralised” as follows::

- if the apartment station calls more than one switchboard (of competence or not) and no one answers, the “**Total calls**” and “**Not managed calls**” counters are increased by 1;
- if one of the switchboards calls the concerned apartment station and it replies (or viceversa), the “**Not managed calls**” counter is reset to zero on all switchboards.

In this way, all switchboards are informed that the concerned apartment station was successfully called.

 *Missed call notification will not be received if a switchboard is in standby mode or if its competence was transferred to another switchboard (see section [Other configurations](#)).*

By pressing on the “**Other configurations**” the following screen is presented:

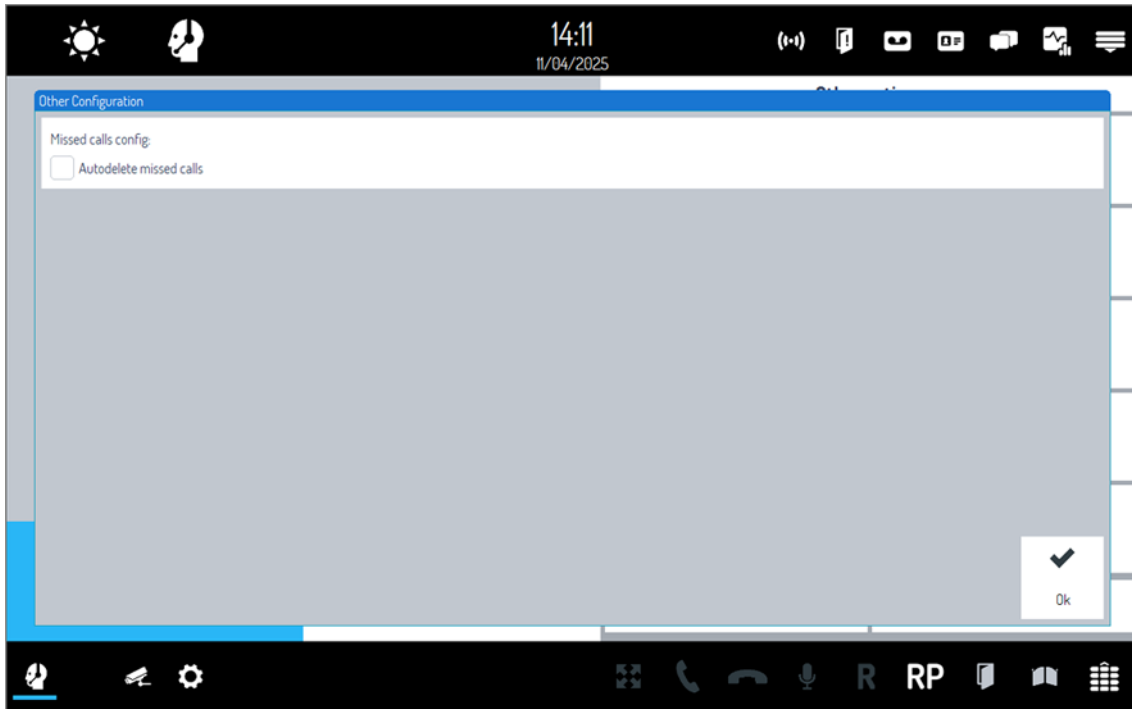

If the item **Automatic cancellation of missed calls** is not selected (default choice), missed calls can be deleted only by pressing on the “Delete” button in the corresponding window. If, on the other hand, the item is selected, missed calls are automatically (and only locally on the PBX on which the option is active) cleared as soon as the attendant calls the apartment extension and it answers the call or vice versa.

#### 5.8.4 ADDRESS BOOK

As already described in paragraph [Call to a user with the address book](#), calls to users/appartements can be executed selecting the name from the related list. To display the list, it is needed to click on button  on the left bar or item “Address book” from “View” menu.

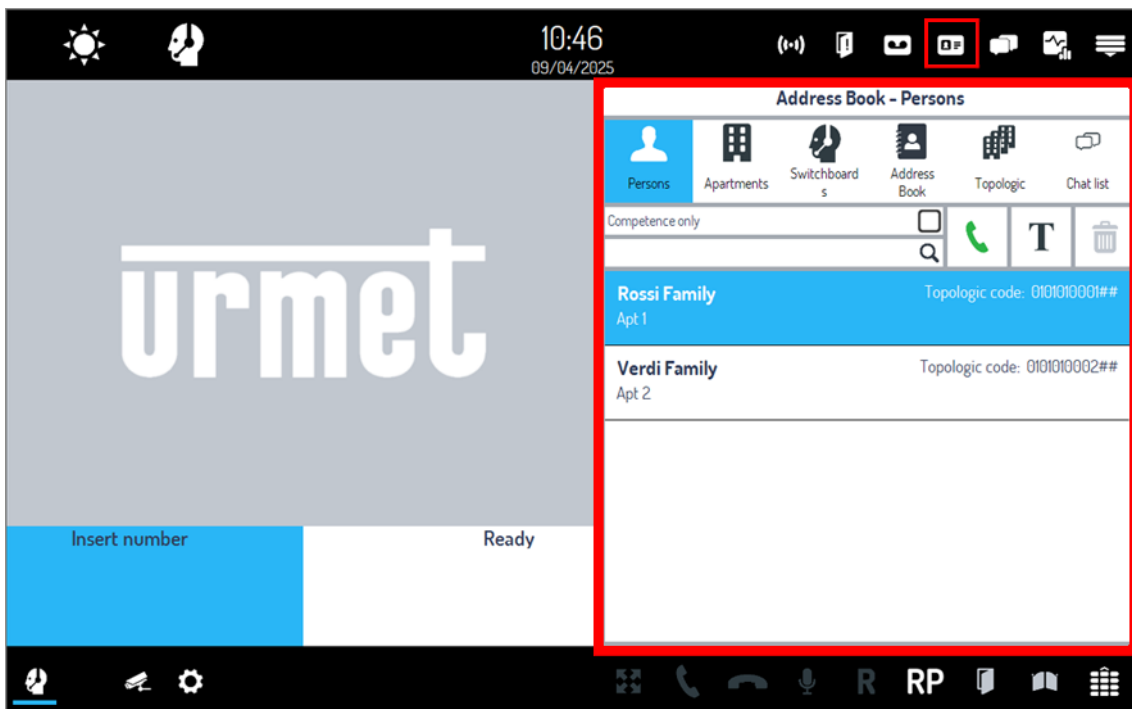

To search a user, it is possible to write the name or a part of it in the white text field above or browse the list in the middle part of the figure above.

After selecting the user to call, it is enough clicking on button  to start the call (the button is enabled when a contact is selected).

At the same way “Apartments”, “Switchboards”, “Address book”, “Topologic” tabs allow calling a specific

apartment, switchboard, contact or video door phone/video door phones as described above in the related paragraph.

### 5.8.5 TEXT MESSAGES

Selecting the icon  from the top control bar displays the list of all chats enabled with the switchboard.



Receipt of a new chat message is visually signalled by the relevant icon  which starts to blink green and acoustically.

The functionality of this item has already been explained in the section [Chat list](#).

### 5.8.6 DIAGNOSTICS

By pressing on the  you can view the diagnostics for each device in the system:

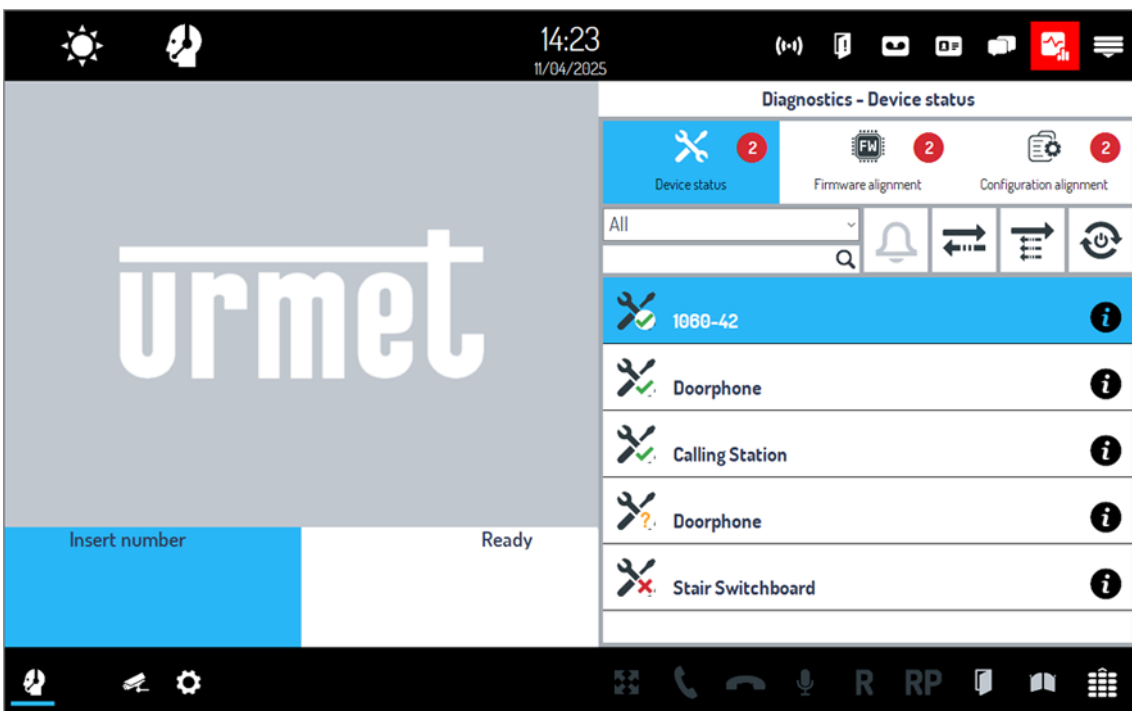

The screen shows the following information:

- operating status, i.e. whether the device communicates correctly with the Switchboard .
- firmware version and alignment, i.e. which firmware version the device has and whether it is aligned with the same software development platform present on the Switchboard.
- configuration file alignment, i.e. whether the configuration file on each device is aligned with the configuration file on the Switchboard.

*Any anomalies on the “Diagnostics” (incorrect communication or misalignment of one or more devices) are highlighted by the Switchboard application by means of acoustic and visual signals (the icon  starts flashing red).*

*The devices must be put in the configuration, so that the “Diagnostics” function can report any anomalies.*

The tabs described above are shown in the figure below (which shows a part of the screen which appears when you press the “Diagnostics” item or the respective button):



The individual tabs are described in greater detail below.

## DEVICE STATUS

The “*Device status*” tab displays:

- the devices that are not communicating correctly with the Switchboard,
- the devices that are communicating correctly with the Switchboard,
- all the devices regardless of their communication status.

An example of a screenshot is shown below:

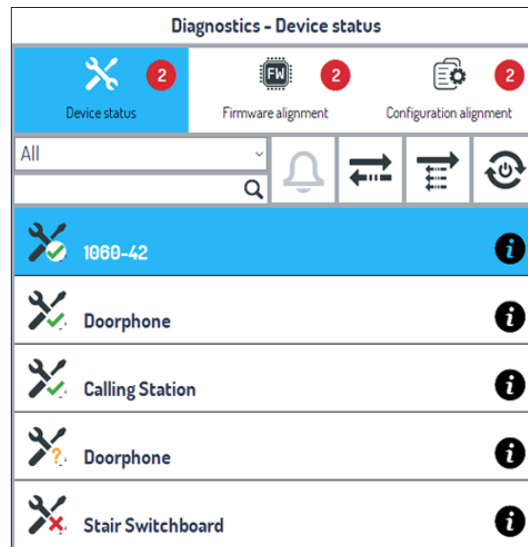

The drop-down menu in the red rectangle can filter devices by items:





- “ **Unreachable** ” (devices that are not communicating properly),
- “ **Reachable** ” (devices that are communicating correctly),
- “ **All** ” (all devices).

The default entry is “**Unreachable**”.

The presence of devices that are not communicating correctly with the Switchboard is indicated by red circles on the respective tab with the corresponding number inside.



The icons indicating correct or incorrect communication with the Switchboard are shown in the rectangle and can be:

- , when the device communicates correctly;
- , when the device is not communicating;
- , when the Switchboard is waiting for a response from the device;
- , when the Switchboard has never communicated with the device (this can happen with large installations).

### FIRMWARE ALIGNMENT

The “**Firmware alignment**” tab displays the following:

- devices whose development platform (UPTK) is aligned with that of the Switchboard,
- devices whose development platform (UPTK) is not aligned with that of the Switchboard,
- all devices regardless of the alignment status of the UPTK platform.

An example of a screenshot is shown below:

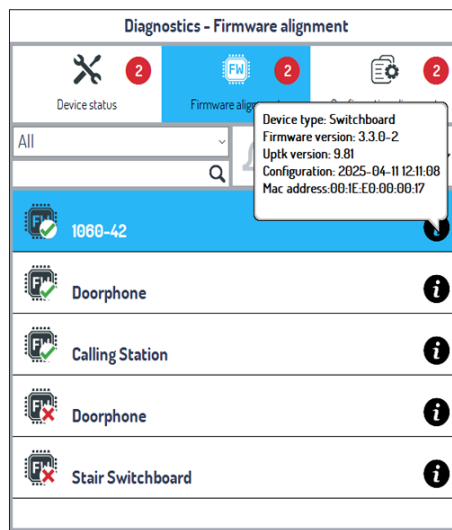

The drop-down menu in the red rectangle can filter devices by items:



- “**Matching**” (devices with UPTK version aligned),
- “**Not matching**” (devices with UPTK version not aligned),
- “**All**” (all devices).

The default setting is “**Not matching**”.

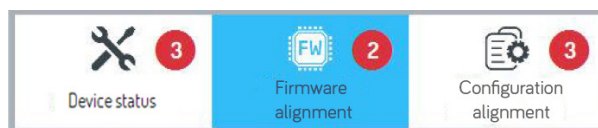
The presence of devices the versions of which are not aligned correctly with the Switchboard is indicated by red circles on the respective tab with the corresponding number inside.



The icons indicating correct or incorrect communication are shown in the rectangle and can be:

- , if the alignment is correct,
- , if the alignment is incorrect.

## ALIGNMENT CONFIGURATION

The Alignment configuration tab displays:

- devices without configuration;
- devices whose configuration is older than that of the Switchboard;
- devices whose configuration is more recent than that of the Switchboard;
- devices whose configuration is the same as the Switchboard;
- all devices regardless of the alignment status of the configuration.

An example of a screenshot is shown below:

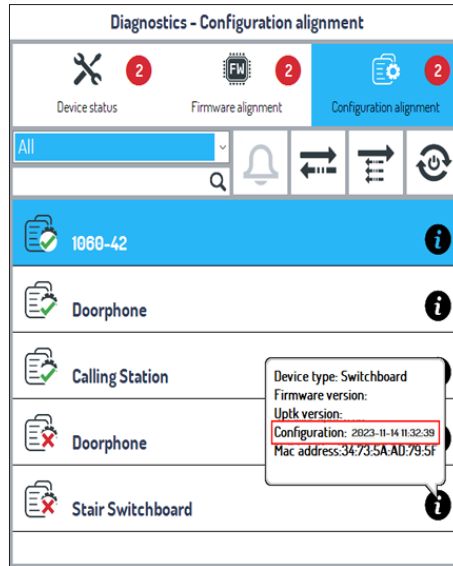

The drop-down menu in the red rectangle can filter devices by items:



- **“Previous configuration/Not configured”** (devices that have no configuration or whose configuration is older than that of the Switchboard),
- **“Most recent configuration”** (devices whose configuration is more recent than that of the Switchboard),
- **“Same configuration”** (devices whose configuration is the same as the Switchboard),
- **“All”** (all devices).

The default setting is **“Previous configuration/Not configured”**.

The presence of devices the configuration file of which are is not aligned correctly with the Switchboard is indicated by red circles on the respective tab with the corresponding number inside.



The icons indicating correct or incorrect communication are shown in the green rectangle and can be:

-  if the alignment is correct,
-  if the alignment is incorrect.



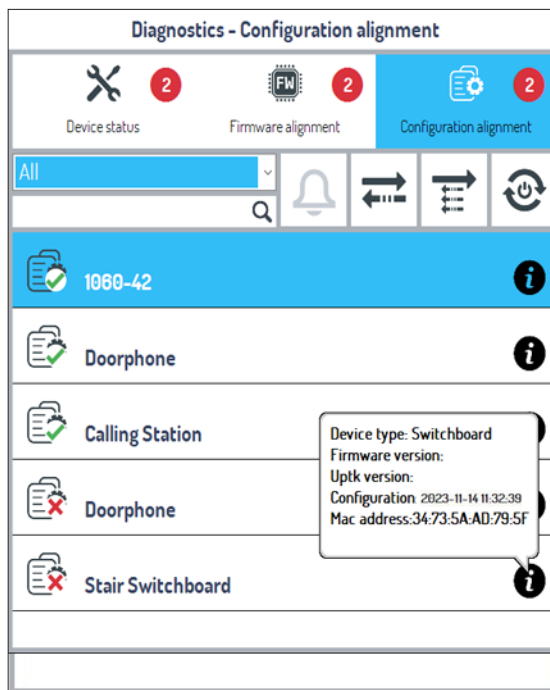

## OTHER INFORMATION

Regardless of the tab chosen for each device, the following information is also displayed by pressing  :

- name (assigned during system configuration);
- type (if calling station, apartment station or other);
- firmware version;
- development platform version (UPTK) incorporated in the firmware version;
- the date the device was configured;
- MAC address.



In addition, always regardless of the tab chosen, it is possible to:

- check whether a single device communicates with the Switchboard via the button (for  the button to enable, you must select a device);
- check whether all devices communicate with the Switchboard via the button  ;
- restart the device using the button (for  the button to enable, you must select a device);
- silence the auditory alert only of device not communicating correctly with the Switchboard using the button  (for the button to enable, you must select a device).

 After silencing the audible notification of a device not communicating correctly with the Switchboard, it no longer appears in the count of devices not communicating correctly (red circle in the “Device status” tab).

 The only notification that can be silenced is the incorrect communication one. Misalignment notifications (of configuration or UPTK software development platform) cannot be silenced, since for the proper operation of the system, the configuration and UPTK version of the devices must necessarily be aligned.

 The RTSP Cameras do not appear in the “Diagnostics” because they are not IPerCom devices.

The field with the magnifying glass  can be used to filter devices by name.

### 5.8.7 OTHER OPTIONS

In the upper function bar, by pressing on the button  , you can display a screen that allows you to configure or display the indicated function. By pressing the “Next” displays the next page with the following functions.



- [Active calls](#)
- [CCTV Cameras](#)
- [Configuration distribution status](#)
- [Door opening](#)
- [Commands](#)
- [System log](#)
- [Real-Time events](#)
- [Lift](#)
- [Test Camera](#)
- [Peripheral configuration](#)
- [Melodies](#)
- [Speaker volume](#)
- [Handset ring level](#)
- [Other configurations](#)
- [Call forwarding](#)
- [Setup Concierge](#)
- [Info](#)

The following pages will describe all the available functions displayed above.

## ACTIVE CALLS

Pressing on “Active calls” opens a window where all calls in progress (active) on the system are displayed:

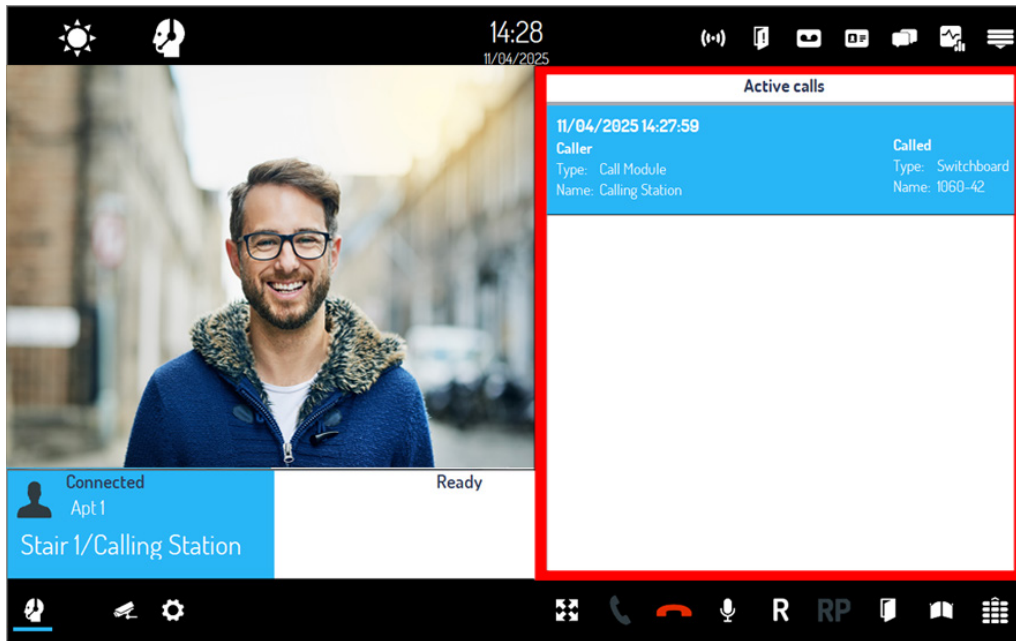

The following information is provided for each call:

- the starting date and time of the conversation,
- name of the calling device and apartment called,
- type of calling and caller device.

As soon as an active call is ended, the respective field is no longer displayed.

- *UnAn auto-on from a video door phone on any IPerCom calling station appears in the list of active calls.*
- *When configuring the IPerCom system it is advisable to give meaningful names to the apartments so that they can be more easily identified in the “Active Calls” window.*
- *If you call a single video door phone, the name of the apartment in which the video door phone is placed will appear.*

## CCTV CAMERAS

Clicking on item “**CCTV Cameras**” from menu “Tools”, all the camera units in the system are displayed. These can be the cameras of the Call Module 1060/12-13-17-18-23, Entry panel 1060/71-74-75-78, Modular Calling Station with 1060/48, Entry panel 1060/21-22-33-34.

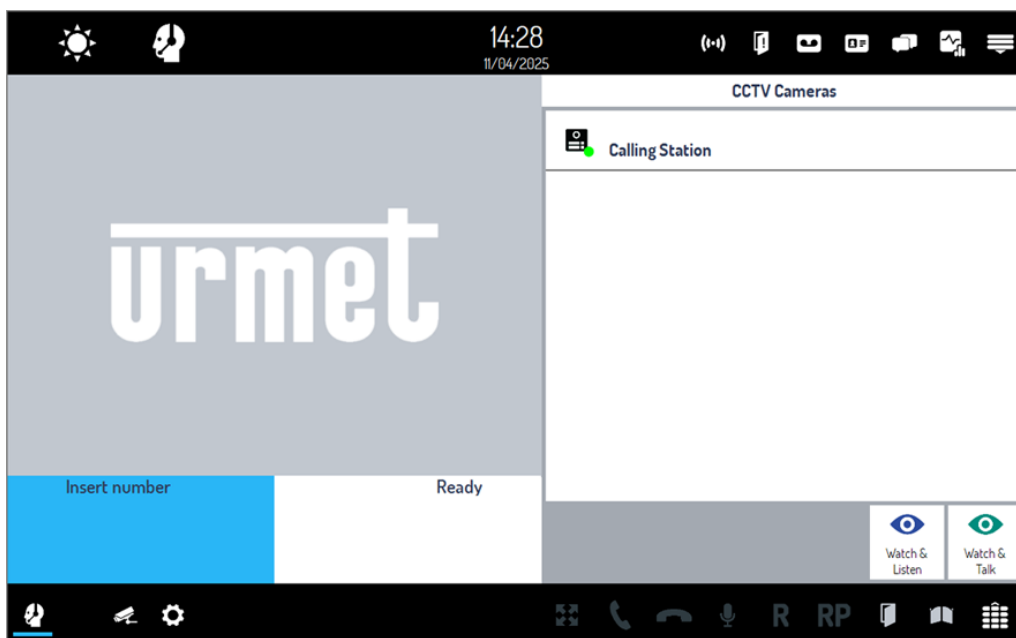

To display images coming from one of these cameras, follow the procedure below:

- select a calling station;
- Click on button “Watch & Talk” to see images and establish a bidirectional audio connection with the camera unit or on button “Watch & Listen” if you only want to view the video stream and listen to the audio coming from the calling station without the ability to communicate.

 In the first case, camera leds will turn on, in the second case they will stay off to keep audio-video control secret.

 Status “Reachable” means that the device is working properly, on the contrary status “Unreachable” means that the device is not working properly. This status is visually represented by a colored dot (green or red) located below the door station icon: green for Reachable, red for Unreachable.

- On the main screen of the switchboard in the video images area, the images taken appear and the call data area panel will indicate the following:

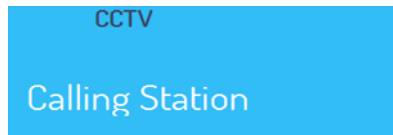

- To break the display of images from a camera, click on button  ;

 Clicking both on button “Watch & Talk” and “Watch & Listen”, it is also possible to activate pedestrian door and / or gate of the device on which user is making auto on.

## CONFIGURATION DISTRIBUTION STATUS

Pressing the “**Distribution**” item in the window that opens will show the configuration status of the devices in the system.



Configuration Status	Count	Action
Devices with the same configuration	12	Show
Devices not in configuration	4	Show
Device from factory or with an older configuration	0	Show
Devices with a newer configuration	0	Show

Make sure that all devices in the system have received the new configuration. This can be seen by checking that the “*Devices with the same configuration*” item shows the number of devices present in the system except for the Switchboard (on which the configuration distribution is checked).

You must also make sure that the “*Devices without or with an older configuration*” and “*Devices with a newer configuration*” items are set to zero.

The “*Devices not in configuration*” item shows any devices connected to the system but not yet included in the configuration.

“*Show*” button opens a window with the list of devices, which are in the same mode related to configuration: if a device is selected, it is possible to send a reboot command.

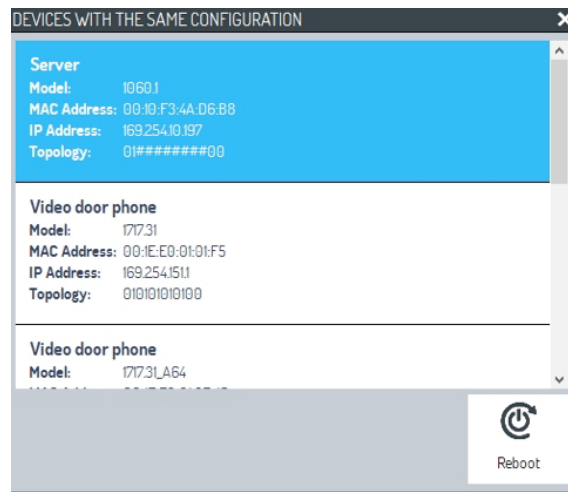



Selecting a reachable device and pressing the  button will restart the device.

## DOOR OPENING

Pressing the “Door opening” item, you can enable the electric locks of the calling stations on the system.



On the calling station you want to use, select the indication with the icon  to select the pedestrian door or the icon  to select the driveway.

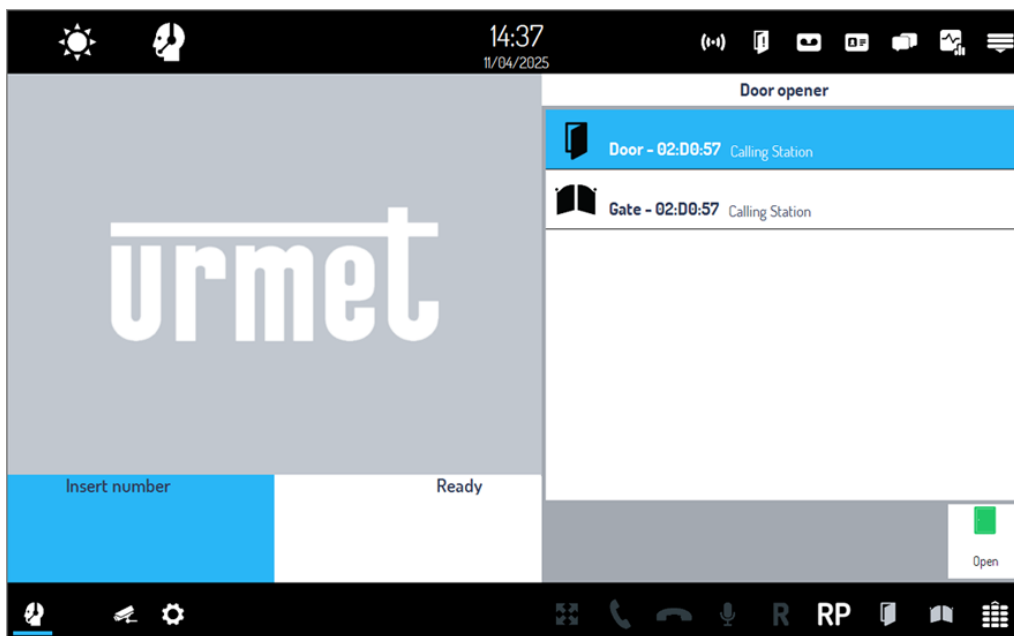



Having selected an opening, press the button  to open the door.

You can also show the status of the doors using the icon  which starts to blink if the door (pedestrian) is still open over the time set (see the [Ipercom technical manual \(ver. 3.2 or higher\)](#) for further details).

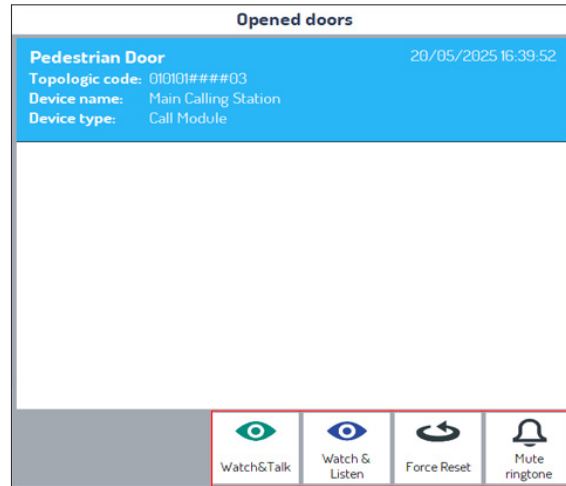
Premendo la medesima icona si apre la finestra seguente in cui sono riportate le informazioni sulle porte rimaste aperte:



 The display of door status from Call Module 1060/12-13-17-18-23, Door Station 1060/71-74-75-78, Door Station 1060/21-33-34, Key Reader 1060/86, and Modular Keypad with 1060/48 is possible only if the appropriate door status sensors (magnetic micro-contacts or equivalent) have been connected to the terminals arranged on these devices.

 Open door alerts are displayed on all switchboards, even those that are not under the jurisdiction of the devices that generated the alert.

For more information on doors left open see the section [Doors left open](#).

## COMMANDS

Pressing the “**Commands**” item, the following screen is shown with various activation types.

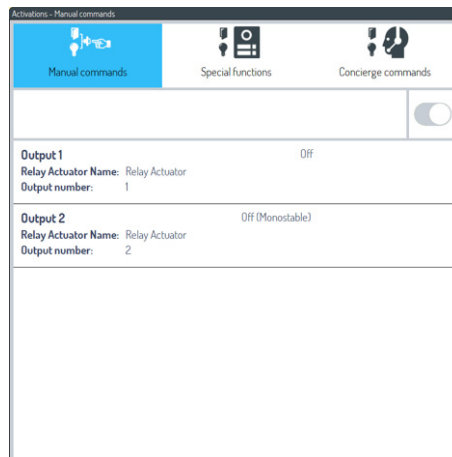

The activations executable from the switchboard are those displayed in the top 3 tabs, viz:

- “**Manual Commands**”,
- “**Special Functions**”,
- “**Switchboard commands**”.

These 3 types of activations are explained in more detail below.

## MANUAL COMMANDS

The “Manual Commands” tab lists all the outputs of Relay Actuator 1060/84 devices present in the system. Depending on how an output has been programmed (whether monostable or bistable), it can be switched on or off or activated (for the time set in the configurator) by pressing the button in the red box:

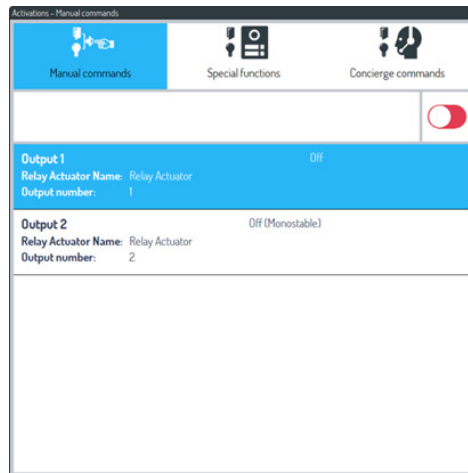

## SPECIAL FUNCTIONS

The “Special Functions” tab shows the list of calling stations (Call Modules 1060/12-13-17-18-23 and/or Modular Calling Station with 1060/48) to which one or more activations with item number have been associated. By selecting one of the calling stations, a significant description of the activation is shown with the relevant item number. When one of the activations has been selected, simply press the “→” button to activate the corresponding relay outputs, as shown below:

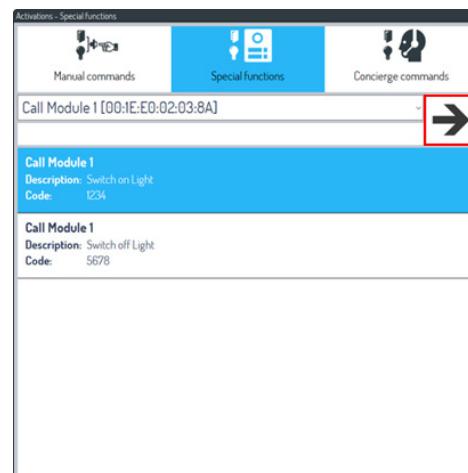

## SWITCHBOARD COMMANDS

The **Switchboard Commands** tab lists all the activations along the topological path of the switchboard and marked as “Activation from Switchboard” in IPerCom configuration (for further information consult the IPerCom Manual).

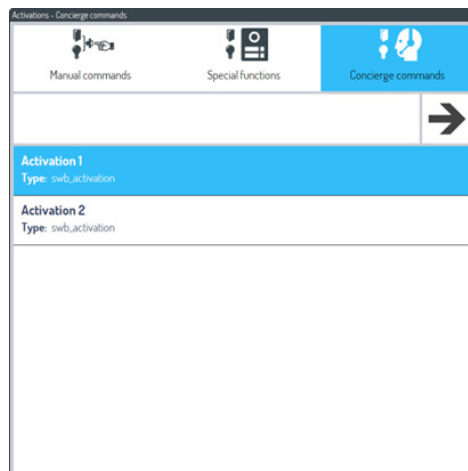

To activate the corresponding relay outputs, simply select an activation and press the “→” button.



## SYSTEM LOG/REAL-TIME EVENTS

The switchboard device can display a series of events relating to operation of an IperCom system (system events). In the menu are the items “*Event History*” (display in static mode) and “*Real-time Events*” (display in dynamic mode).

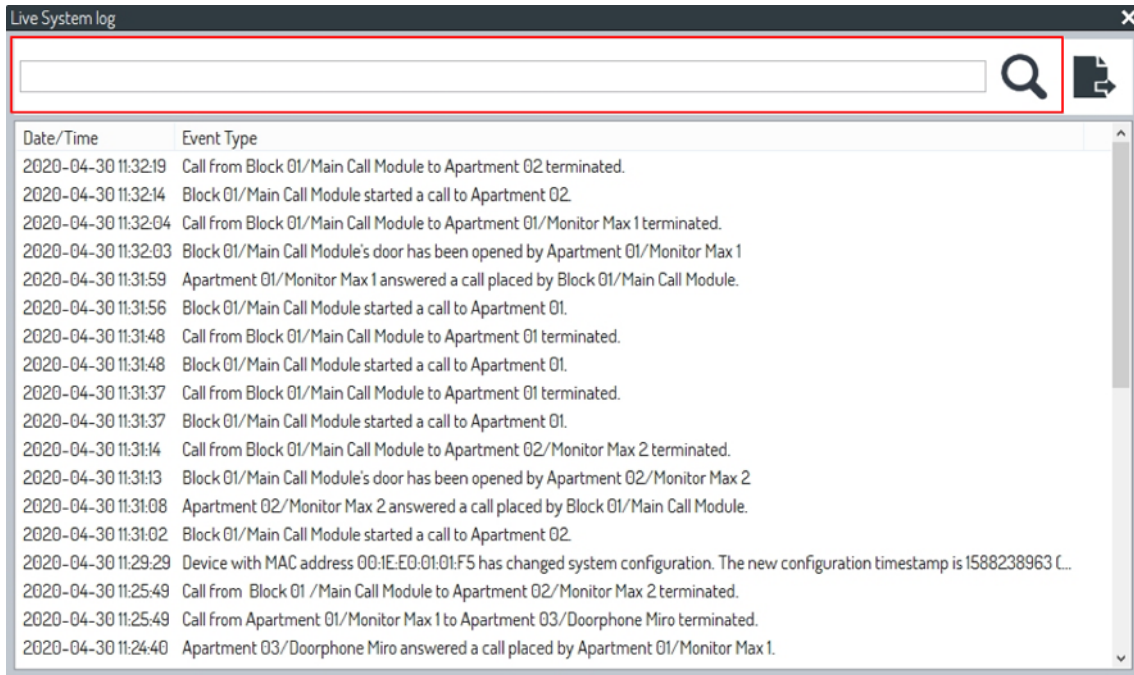
The “Events in real time” button shows in real time all the events starting from the instant in which the switchboard device is on.



The only operations allowed are:

- filtering the events according to a string entered in the red box (after pressing the button );
- exporting the events on PC to a csv file format, after pressing the button .

To export the CSV file, a USB pen must be connected, otherwise an error message with the following pop-up will be shown: “**Removable disks not found**”.

The “Events Log” button instead opens a window with a static display of the events over a time interval of one week starting from the current date (as outlined in the red box):

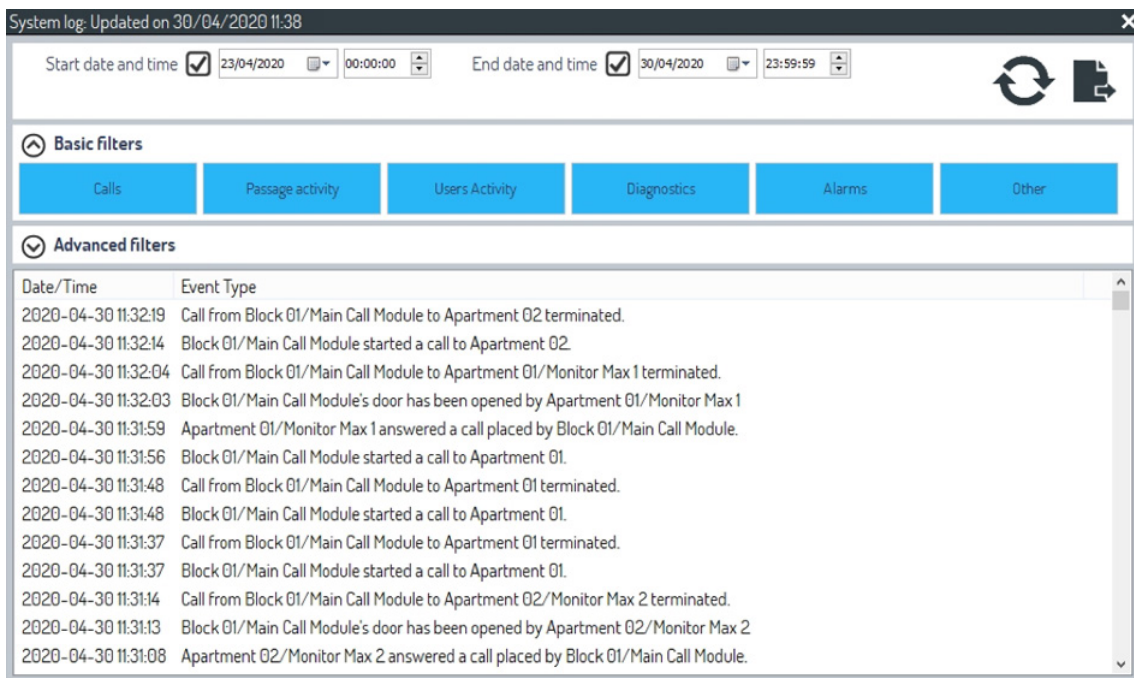

**ATTENTION!** The Events log function is only available if there is at least one server Ref. 1060/1 on the system.

It is of course possible to change the time interval to display events before one week from the current date.

By pressing the button , you can update the system log to the current instant time. By pressing this button, the time on the left side of the grey bar of the screen is updated to the current time:

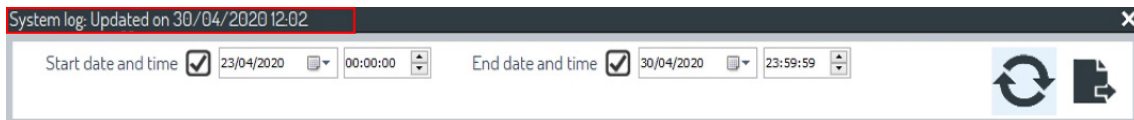

The button  can be used to export the system log to an external file in csv format. A USB flash drive must be connected to the device in order to export the CSV file, otherwise an error message will be displayed with the following popup: **“No removable disks were detected”**.

The Basic Filters and Advanced Filters sections can be used to filter operations as described in the paragraph [How to filter system events](#).

### How to filter system events

The **Basic Filters** and **Advanced Filters** sections appear only by pressing on the “System Log” item (in systems with at least one Server 1060/1) as shown below:

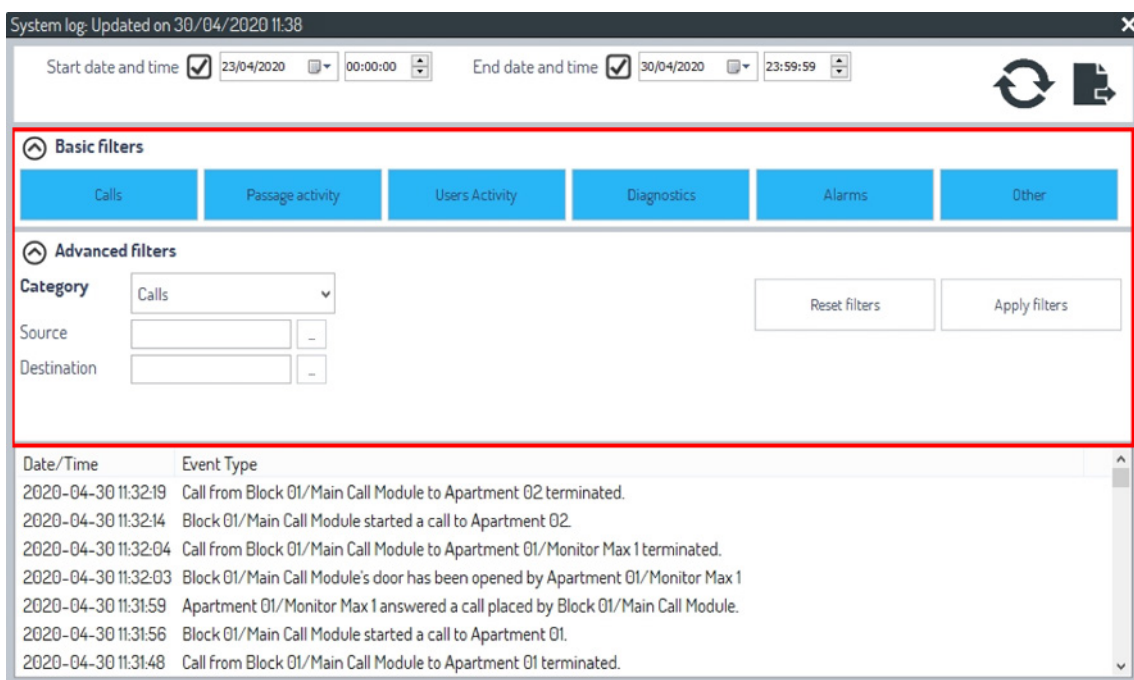

Whenever the system log window is opened (on first start-up of the switchboard) all the buttons related to the event category in the **Basic Filters** section are blue, i.e. selected: this means that the Switchboard application displays all the events and no basic filters have been applied. To deselect an event and therefore automatically not display it, you need to press one of the relevant buttons: its color changes from blue to white..

A more detailed explanation of the various categories of events is now given.

### CALLS

The “Calls” event category comprises all types of calls between the various devices in the system (including auto-on events). For each call, the source device (that starts the call), the destination device (that receives the call), the possible answer and the end of the call are displayed in detail. The name of each device is preceded by the name of the topological node where the same device was placed. An example is shown below:

Date/Time	Event Type
2020-04-30 11:32:19	Call from Block 01/Main Call Module to Apartment 02 terminated.
2020-04-30 11:32:14	Block 01/Main Call Module started a call to Apartment 02.
2020-04-30 11:32:04	Call from Block 01/Main Call Module to Apartment 01/Monitor Max 1 terminated.
2020-04-30 11:31:59	Apartment 01/Monitor Max 1 answered a call placed by Block 01/Main Call Module.
2020-04-30 11:31:56	Block 01/Main Call Module started a call to Apartment 01.

## PASSAGES ACTIVITIES

The “*Passage activity*” event category includes the opening of all the device gates (pedestrian entrances and driveways) from apartment stations, resident/non-resident (using door opener code or proximity key), hall button, trade function and switchboard. The name of each device to which the passage belongs is preceded by the name of the topological node where the same device was placed. An example is shown below:

Date/Time	Event Type
2020-04-30 11:59:20	Block 01/Main Call Module's door has been opened by Resident 1
2020-04-30 11:57:57	Block 01/Main Call Module's door has been opened by Apartment 01/Monitor Max 1
2020-04-30 11:57:33	Block 01/Main Call Module's gate has been opened by Apartment 02/Monitor Max 2
2020-04-30 11:57:29	Block 01/Main Call Module's door has been opened by Apartment 02/Monitor Max 2

 For the trade function, see the [Ipercom technical manual \(ver. 3.2 or higher\)](#).

## USER ACTIVITIES

The “*User Activities*” event category includes for residents and non-residents the request to open a gate (pedestrian entrances and driveways) with proximity keys or door opener code and the related result, the assignment/removal/suspension/restore of a key code, the assignment/suspension/reset of a door opener code.

It is also shown the MAC address of the device from which the assignment/removal/suspension/restore of the key code or door opener code was performed. The name of each device, to which the gate belongs, is preceded by the name of the topological node where the same device was placed. An example is shown below:

Date/Time	Event Type
2020-04-30 12:37:44	Configuration changed by MAC 00:1E:E0:01:01:F5: door code 6**2 has been suspended for user Resident 2 to use
2020-04-30 12:37:...	Resident 2 requested Block 01/Main Call Module to open of the door or gate using a open door key code. Request approved.
2020-04-30 12:36:...	Resident 1 requested Block 01/Main Call Module to open of the door or gate using a open door key code. Request approved.
2020-04-30 12:36:...	Configuration changed by MAC 00:1E:E0:01:01:F5: door code 6**2 has been added for user Resident 2

## DIAGNOSTICS

The “*Diagnostics*” event category includes information for each device if it is no longer reachable and when it is reachable again. The name of each device is preceded by the name of the topological node where the same device was placed. An example is shown below:

Date/Time	Event Type
2020-04-30 12:53:...	Video door phone Apartment 02/Monitor Max 2 (MAC 00:1E:E0:01:3F:45) is reachable again
2020-04-30 12:51:15	Video door phone Apartment 02/Monitor Max 2 (MAC 00:1E:E0:01:3F:45) cannot be reached
2020-04-30 12:49:12	Video door phone Apartment 01/Monitor Max 1 (MAC 00:1E:E0:01:01:F5) is reachable again
2020-04-30 12:47:12	Video door phone Apartment 01/Monitor Max 1 (MAC 00:1E:E0:01:01:F5) cannot be reached

## ALARMS

The “*Alarms*” event category includes all the alarms generated by IPerCom system. In detail, it shows which device has generated a specific alarm, which switchboard has taken charge of the alarm and which switchboard has reset it. The name of each device is preceded by the name of the topological node where the same device was placed. An example is shown below:

Date/Time	Event Type
2020-04-30 13:02:55	Alarm Coercion, raised by Block 01/Main Call Module, has been reset by Block 02/Switchboard
2020-04-30 13:02:48	Alarm Coercion, raised by Block 01/Main Call Module, is requested to be handled by Block 02/Switchboard
2020-04-30 13:02:41	Alarm Coercion, raised by Block 01/Main Call Module, has been handled by Switchboard
2020-04-30 13:02:17	Alarm Coercion raised by Block 01/Main Call Module

## OTHER

The event category “*Other*” includes other events that do not fall into the above categories. In detail, it includes events related to the Lift Interface, log in and log out events from the switchboard, MAC address of the device from which a system configuration change or installer password change has been made.

Date/Time	Event Type
2020-04-30 14:12:36	Switchboard user User 1 has successfully logged in on Block 02/Switchboard
2020-04-30 14:12:31	Switchboard user User 1 has failed to log in on Block 02/Switchboard
2020-04-30 14:10:58	Switchboard user User 1 has logged out on Block 02/Switchboard
2020-04-30 13:15:11	Device with MAC address 00:1E:E0:01:01:F5 has changed system configuration. The new configuration timestamp is 1588245306 [...]

Each event category can be further filtered by means of the **Advanced Filters** section, where a drop-down menu shows the various event categories reported before: according to the event category selected, a further filter is shown, as explained in more detail below.

## CALLS EVENT

The following appears if you choose the “Calls” event type in the “Category” drop-down menu (default setting):

The calls can be filtered according to the calling device (“Source”) and the called device (“Destination”). The source and destination are selected by pressing the button . It opens a screen through which you can navigate the topological structure of the system and choose a calling station for the source, as shown below:

The called device is selected in the same way.

After pressing the “OK” button and then the “Apply Filters” button, only calls between the devices selected above for the Calls event category will be displayed.

## PASSAGES ACTIVITIES EVENT

The following appears if you choose the “Passages” event type in the “Category” drop-down menu:

By selecting one or more gates from those shown and after pressing the “Apply Filters”, relative to the event category Varchi Activity, only events related to the opening of the selected varchi will be displayed.

## USER ACTIVITIES EVENT

The following appears if you choose the “User Activity” event type in the “Category” drop-down menu:

By selecting one or more residents/non-residents from those shown and after pressing the “*Apply filters*”, with respect to the event category User Activities, the requests for opening gates (with proximity key or door opener code) and related outcome of only the selected residents/non-residents will be displayed. Also with respect to the selected residents/non-residents, the events of assigning, removing, suspending, restoring a key code and assigning, suspending, restoring a door opener code with MAC address of the device from which the operation in question is performed are also displayed.

## DIAGNOSTICS EVENT

The following appears if you choose the “*Diagnostics*” event type in the “*Category*” drop-down menu:

By selecting one or more devices from those shown and after pressing the “*Apply filters*”, relative to the event category “*Diagnostics*”, only the diagnostic events of the selected devices (reachable or unreachable) will be displayed.

## ALARMS EVENT

The following appears if you choose the “*Alarms*” event type in the “*Category*” drop-down menu:

Selezionando una o più tipologie di allarme tra quelle riportati e dopo aver premuto il pulsante “*Applica filtri*”, relativamente alla categoria di evento “*Allarmi*”, verranno visualizzati solo gli eventi relativi agli allarmi scelti.

## OTHER EVENTS

The following appears if you choose the “*Other*” event type in the “*Category*” drop-down menu:

By selecting one or more alarm types from those reported and after pressing the “*Apply filters*”, relative to the event category “*Alarms*”, only the events related to the selected alarms will be displayed.

## HOW TO CANCEL PREVIOUSLY SET FILTERS

To cancel the filters previously set in the **Advanced Filters** section simply press the “*Reset Filters*” button.

## VIEWING EVENTS

For each event, the data that characterizes it and helps to identify it are reported, i.e. date and time and a brief description of the event.



 The maximum number of recordable events is set to 10.000 by default. Once this number is reached, the oldest events are deleted. The number of events that can be recorded can be modified for special needs up to a maximum of 100.000. This value can be modified by the IPerCom configurator (see the [system technical manual for the installer](#)). The limit has effect only on the “System Log” but not on “Live System log”.

## LIFT INTERFACE COMMANDS

If in the IPerCom system there are one or more Lift Interfaces, it is possible to enable the lifts so that the resident or non-resident can reach the desired floor or apartment according to the operating mode (set on the stair node) where the concerned Lift Interface is positioned. Press the “**Lift interface commands**” item to do this. The following message will appear:



To enable the lift, select the block, stair, and floor (or apartment) on the left side of the screen (marked “**Topological code**”) that the resident (or non-resident) wants to reach. On the right side of the screen (marked “**Activation time**”) you can choose the time for which the lift remains enabled to reach a specific floor or apartment. The “**ACTIVATE**” and “**DEACTIVATE**” buttons activate and deactivate the previously selected time..

-  The selection of the floor or apartment in the left part of the previous figure depends on the operating mode of the Lift Interface (if floor or apartment mode). For more details see [lpercom technical manual \(ver. 3.2 or higher\)](#).
-  On the Lifts Interface configuration page, it is necessary to add the switchboard path to choose the floors and apartments. For more details see [lpercom technical manual \(ver. 3.2 or higher\)](#).

## TEST CAMERA

Pressing the “**Test Camera**” item, you can start a test to display in real time what the webcam integrated in the device has captured or from the external webcam, if this is connected.

If in the **Peripheral configuration** menu in the **Camera** item the **Static Image** parameter was selected as output video, the static image is also displayed in the camera test.

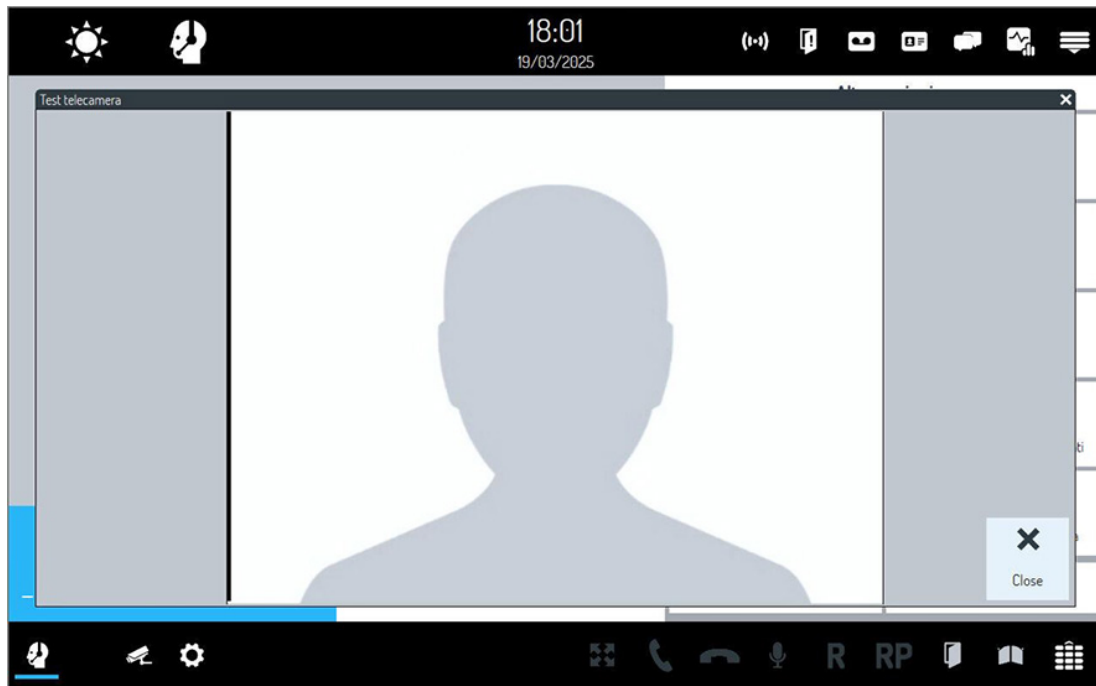

## PERIPHERAL CONFIGURATION

Pressing the “**Peripheral configuration**” item, you can change the peripherals (among those connected on the device) to communicate and capture images from the switchboard.

The window appears as follows:

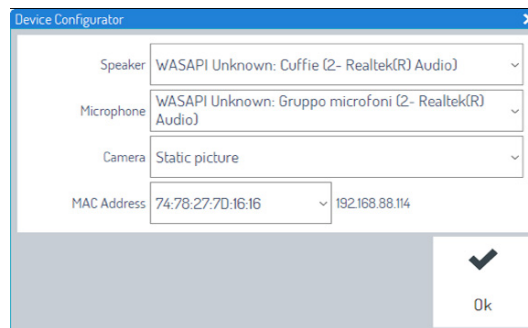

An external camera can be connected to the switchboard to display the video flow. The compatible camera is Ref. 1375/817.

With “**OK**” button it is possible to confirm the changes. In order for the changes to take effect, it is necessary to reboot the device.

## MELODIES

To change the melodies reproduced by the switchboard based on the various calls or events, you must access the window outlined below using the “Melodies” item.

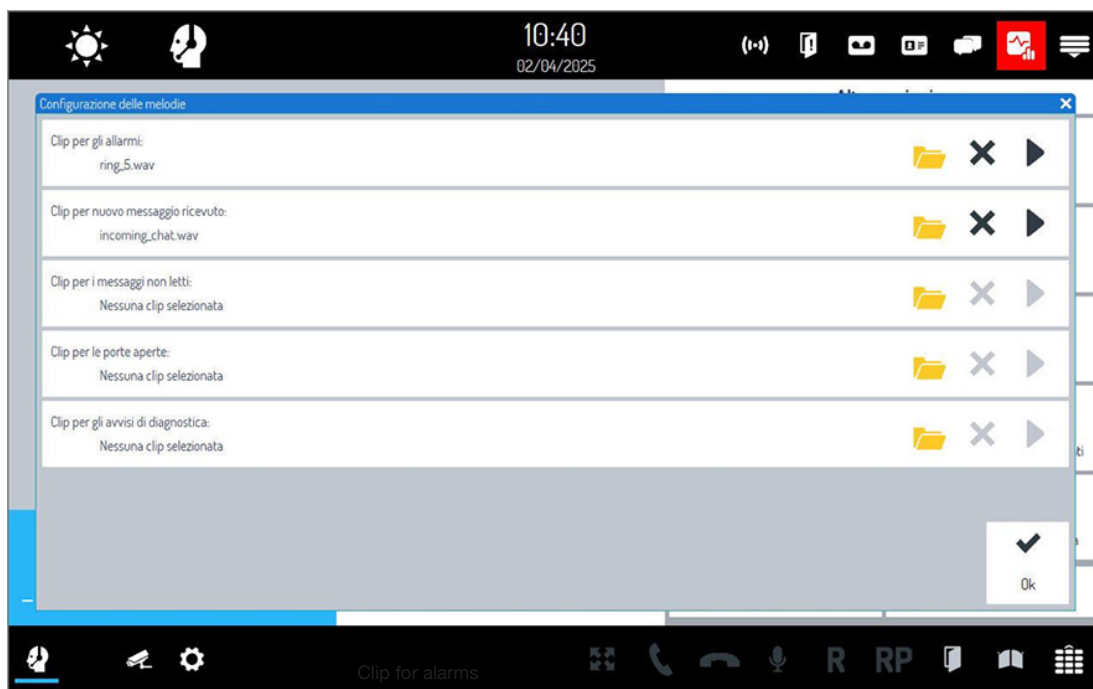

The button  can be used to select a melody from those proposed.

The button  can be used to play the previously selected melody (it is enabled as soon as a melody has been selected).

The button  can be used to delete the previously selected melody (it is enabled as soon as a melody has been selected).

The melodies are played at the following events:

<b>Clip for alarms</b>	Audio file played in case of an incoming alarm
<b>Clip for new chat message</b>	Audio file played for a new chat message received
<b>Clip for not read chat messages</b>	Audio file played for not read chat messages (disabled by default)
<b>Clip for open doors</b>	Audio file played for open doors (disabled by default)
<b>Clip for diagnostic alerts</b>	Audio file played in case of devices not working, not aligned as firmware version or configuration file (disabled by default)

## SPEAKER VOLUME

Pressing the “**Speaker volume**” item, you can adjust the volume of the speakers.



To adjust the speaker volume, move the adjustment bar shown on the display.  
Pressing directly on the icon, you can disable the volume of the speakers.

## HANDSET RING LEVEL

Pressing the “**Handset ring level**” icon, you can adjust the ring volume of the inbound call.



To adjust the microphone volume, move the adjustment bar shown on the display.  
Pressing directly on the volume icon, you can disable the volume of the microphone.

## OTHER CONFIGURATIONS

Press the “**Other configurations**” item to open the following screen:

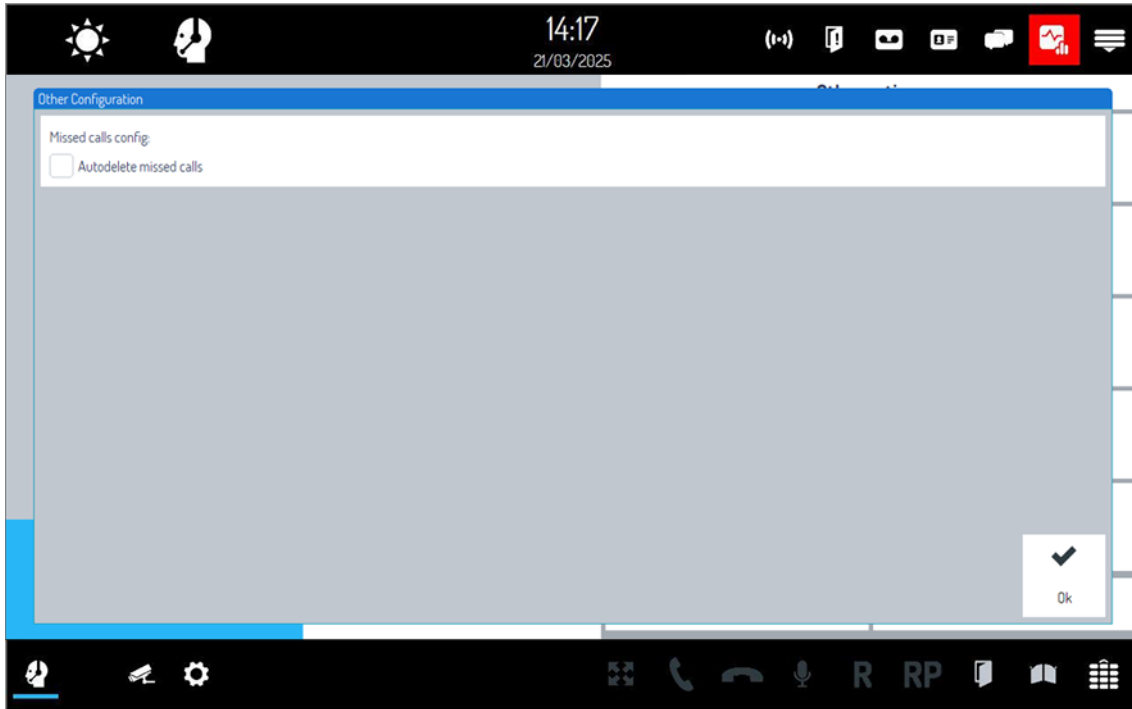

If the “**Autodelete missed calls**” item is not selected (default choice), missed calls can only be deleted by pressing the “*Delete*” button in the missed calls window. If, on the other hand, the item is selected, missed calls are automatically deleted (and only locally on the switchboard on which the option is active) as soon as the switchboard operator calls the apartment station and it answers the call or vice versa..

## CALL FORWARDING

The item “**Call Forwarding**” allows you to:

- activate the call forwarding service on the smartphone/tablet (Android or iOS) on the switchboard;
- verify that the activation was successful.

For all details follow what is given in the paragraphs [APPENDIX A: Configuring the call forwarding function](#).

*Please note that to activate the service correctly, it is also necessary:*

- *appropriately configure the call forwarding function on the configurator;*
- *install the CallMe app on your smartphone/tablet and register with a valid account;*
- *make sure your smartphone/tablet and the IPerCom system have access to the Internet.*

*To actually use the service, it must also be enabled, as explained in the previous section.*

## CONCIERGE SERVICE CONFIGURATION

Press “Concierge Service Config” item to display the following screen:

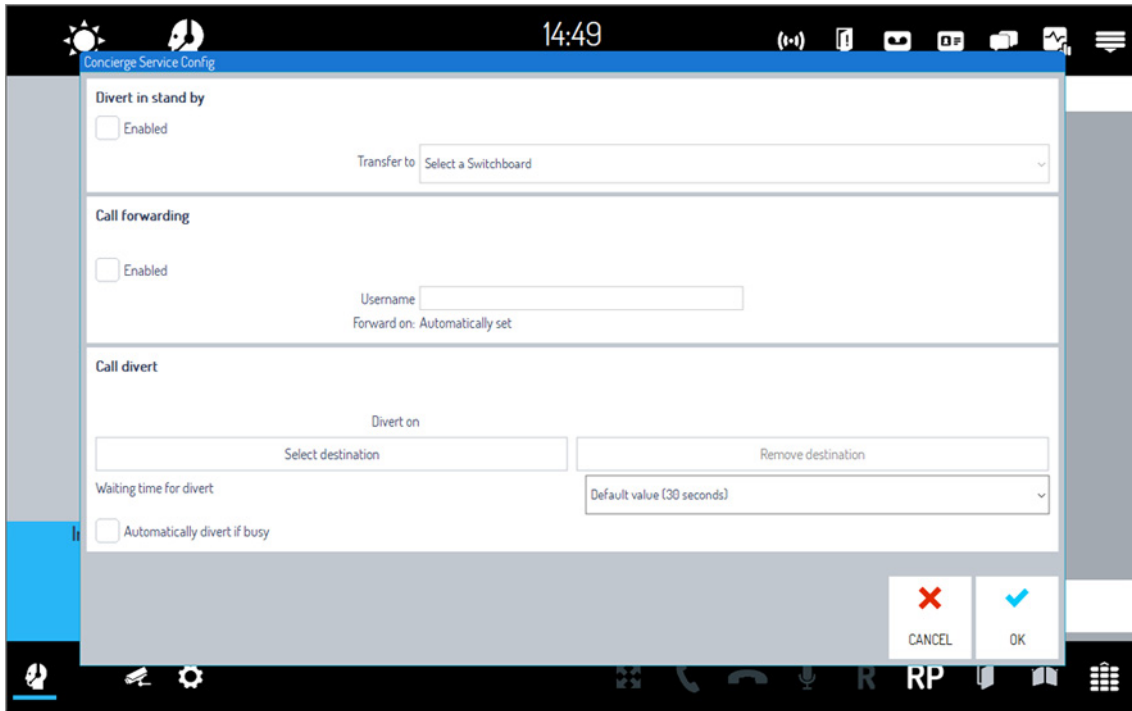



The 3 sections present in the screen are described below.

### TRANSFER IN STANDBY MODE

In this section it is possible to transfer the calls directed to a switchboard in stand-by status to another switchboard available on the system. The switchboard in standby mode will not receive any calls. The destination PBX will assume the behavior expected for the standby PBX, including handling calls according to the currently active mode (e.g., day mode).

To do the above it is necessary:

- check flag “Enabled”,
- select from drop down menu another switchboard of the system,
- click on button  to confirm the choices made before.

In this condition stand by switchboard shows the following icon :  .  
The icon is shown on the top left-hand bar.

### CALL FORWARDING

In this section it is possible to enable the call forwarding function on Android/iOS smartphones and/or tablets, if the switchboard is in day or night mode. In this condition, a call directed to the switchboard will make one or more smartphones/tablets ring in addition to the switchboard.

To do this it is necessary:

- check flag “Enabled”,
- click on button  to confirm the choices made before.

The setting of the feature is displayed by icon  . The icon is displayed in top left-hand bar.

 If the call forwarding function is configured for the first time, the icon  is activated automatically.

 Divert and call forwarding functions cannot be enabled at the same time.



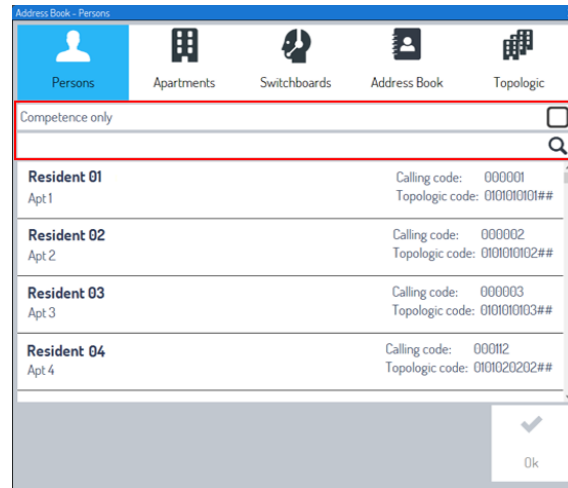

### CALL DIVERT

In this section it is possible to divert the call to the switchboard to one or more apartment stations of the system or to another switchboard. In this condition, a call directed to the switchboard will cause the switchboard to ring first and then, after a preset time, the new selected destination. The divert modes are described below.



The “*Select Destination*” button allows determining who to divert the call to. The following screen opens:



It is possible to divert the call to:

- a user (  tab),
- an apartment (  tab),
- another switchboard (  tab),
- a contact present in the apartment station directory of the system (  tab),
- one or more apartment stations of an apartment (  tab).

 *Call divert to a user, contact or apartment causes all video door phones associated with the user, contact or apartment to ring.*

 *The  tab allows selecting an apartment or its single video door phone by browsing the topological structure of the system.*

The “*Competence Only*” item (red box), if selected, allows reducing the list of users to those whose competence switchboard is the switchboard in question (this item affects also the “*Apartments*” tab).

To quickly search for a user, simply write his/her name or a part of it in the field with the magnifying glass (red box): in this way only users whose name contains the characters entered will be displayed. This also applies to “*Apartments*”, “*Switchboards*” and “*Address Book*” tabs.

When an apartment has been selected (for example), the name of the apartment with its topologic code is displayed:

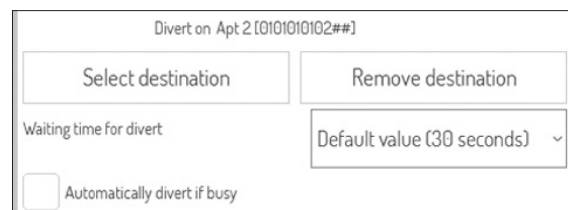



 *If the switchboard call is diverted to a user, the apartment name associated to that user is shown in the figure above.*

The “*Remove Destination*” button removes the previously selected destination.

The “*Waiting Time for divert*” drop-down menu allows setting the time after which the call should be diverted in case of no answer (among the various options there is also the possibility of making an immediate diversion).

The “*Automatically divert if busy*” option immediately diverts the call if the switchboard is busy.

Enabling of this function is indicated by the  (if the switchboard is in “*Day*” or “*Night*” mode).

 *If the Switchboard application is diverted to one or more apartment stations in the system, the call from the CallMe application to the Switchboard application is not supported.*

 *Divert and call forwarding functions cannot be enabled at the same time.*

## INFORMATION ABOUT SWITCHBOARD

To display information relating to the IP and MAC addresses of the switchboard and the software version, select the “Info” item. The following screen appears:

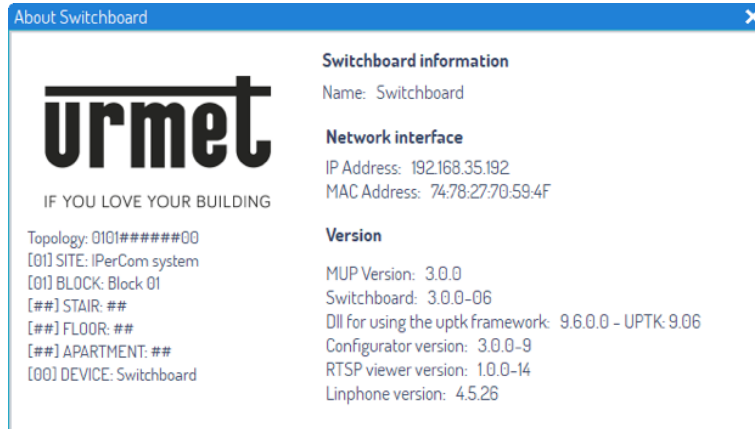

## 5.9 EXTERNAL CAMERAS (RTSP)

Selecting the following icon  displays the screen where images from any RTSP cameras in the system are shown.

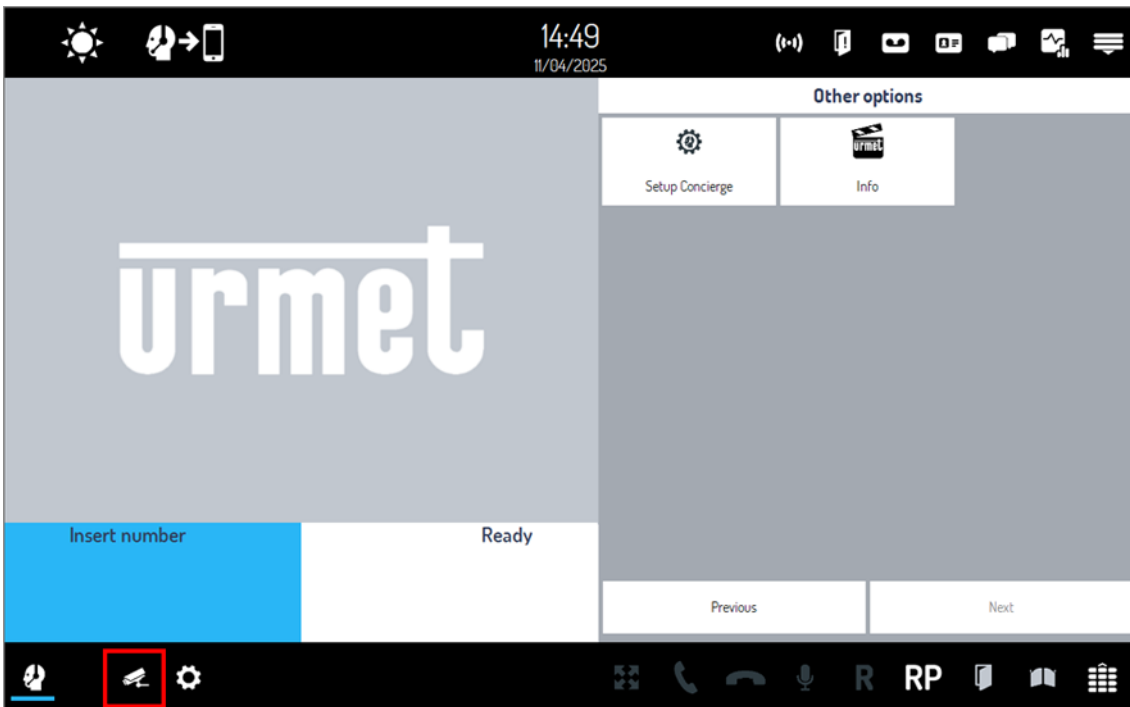

After pressing the icon, the following screen appears.

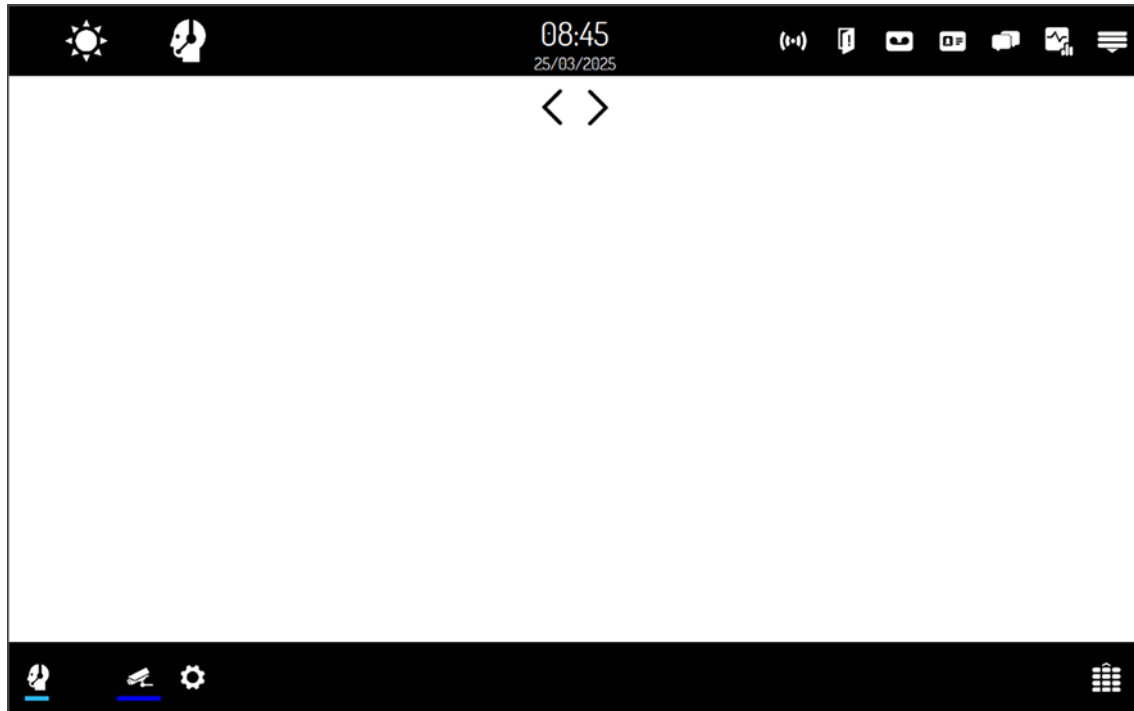

Pressing the buttons < or > you can display the image captured by the RTSP camera after short loading.

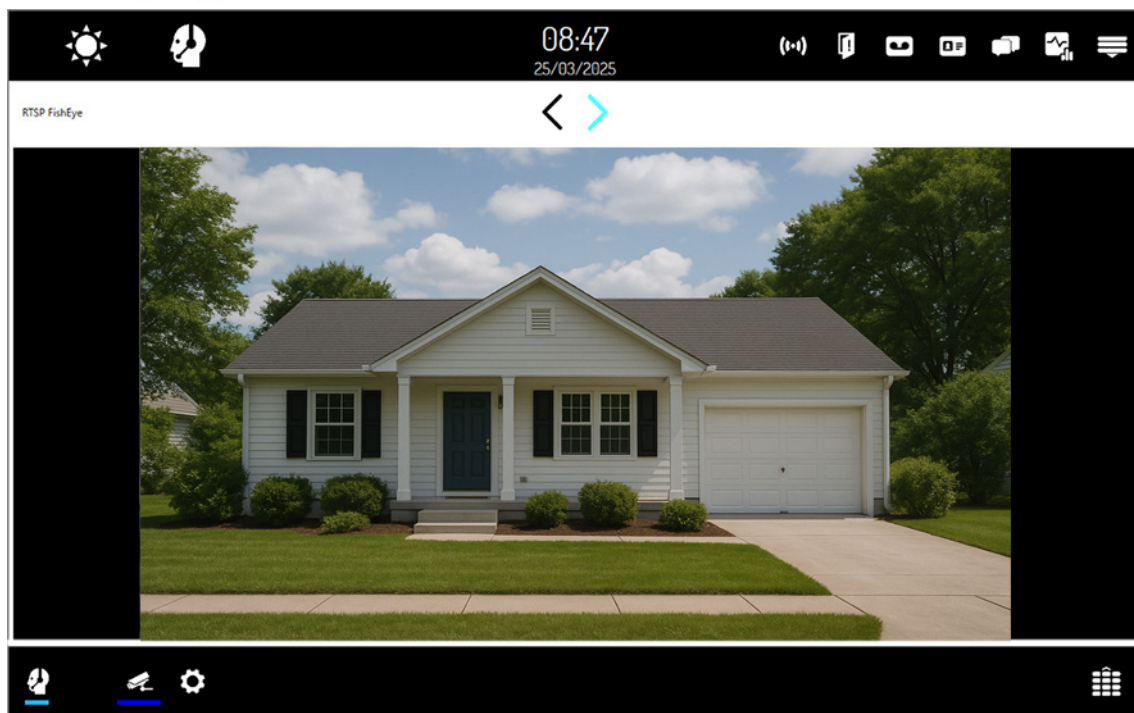

Pressing the < or > buttons again, you can scroll between the next camera and the previous one and show what was captured.

*In the RTSP cameras display, all the IPerCom calling stations appear if the settings relating to the RTSP flow were correctly configured by the configurator (see the **Installer's technical manual of the IPerCom system** for further details). The video flow is only shown in the sending phase of a call to an apartment and in the subsequent conversion phase or if from the video door phone indoor set auto-insertion is carried out.*

### 5.9.1 ACCESS CONTROL

To access this functionality, the following icon  must be pressed, found on the lower bar and access the Ipercom configurator.



The configurator enables management of IPerCom’s access control system. In detail it is possible to:

- create/change users and user group (residents, not residents and switchboard users);
- create/change access rules for users or user groups of the system.

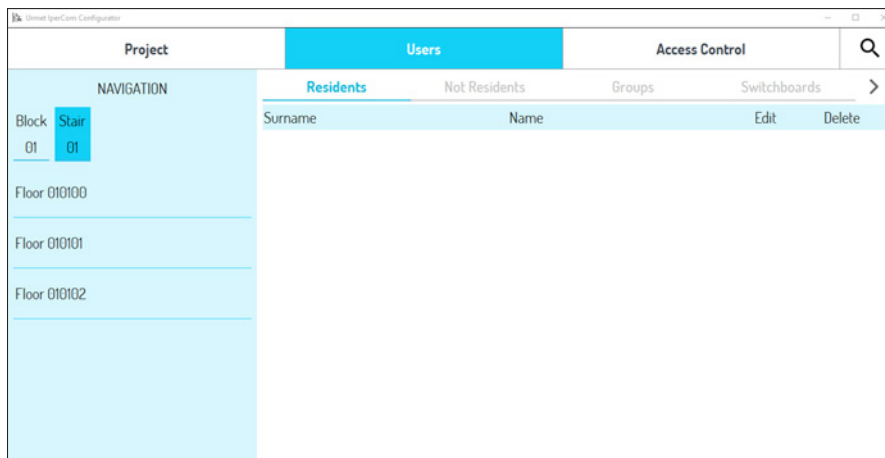

To create new residents, new not residents, user groups and switchboard users, see [technical manual for the installer](#).

*If a video door phone of the system has opened the configurator or another switchboard has already launched the “Access control” function, it is not possible to launch the same feature from another switchboard.*

Once the changes have been made, press the “Apply” button on the “Project” tab and wait for the new configuration to be distributed to all the devices in the system.

## 6 PROBLEM SOLVING

### 6.1 MISMATCH BETWEEN SOFTWARE VERSIONS OF DEVICES

If there is misalignment between the software versions of the devices and/or the applications, it is signaled by the switchboard with the following message:



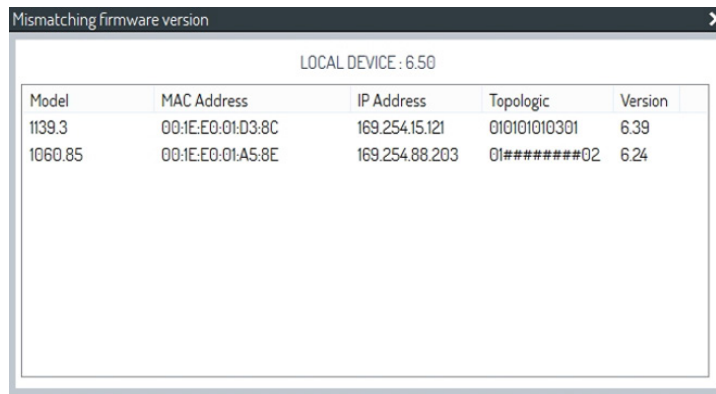

By pressing the "Status" button, you can view the list of devices whose software version is not aligned with the Switchboard application, as shown below:



A table titled "Mismatching firmware version" with a subtitle "LOCAL DEVICE : 6.50". The table has five columns: Model, MAC Address, IP Address, Topologic, and Version. It lists two devices with mismatching versions.

Model	MAC Address	IP Address	Topologic	Version
1139.3	00:1E:E0:01:D3:8C	169.254.15.121	010101010301	6.39
1060.85	00:1E:E0:01:A5:8E	169.254.88.203	01#####02	6.24

 The software versions shown in the figure refer to the software development platform version included in the release software version.

 The devices must be inserted in the configuration, so that the Switchboard application can report any mismatches.

The message temporarily disappears when you press the "OK" button. However, all the devices in the plant must be aligned with the same firmware version for the plant to work correctly..

### 6.2 SERVER UNREACHABLE

With IPerCom systems in IPerCloud mode, where a Server 1060/1 is required, the switchboard signals its absence with the following warning message:

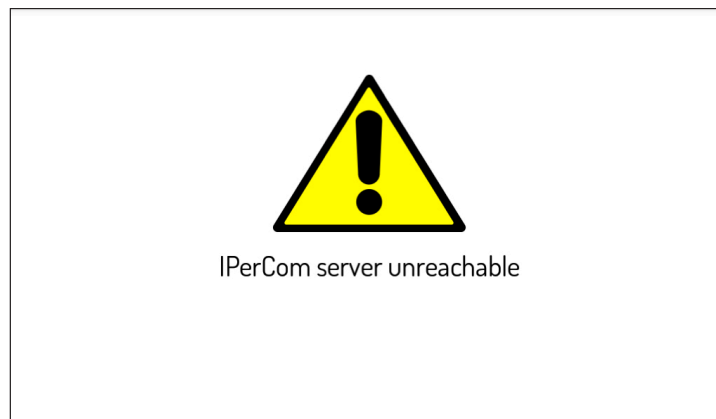

If this message appears, the switchboard is no longer usable. You need to restore correct operation of the Server 1060/1 so that the above message disappears and you can use the switchboard again.

## APPENDIX A: CONFIGURING CALL FORWARDING FUNCTION

Configuration of the call forwarding function with the support of the CallMe Manager application is provided for all those types of facilities where there is a condominium administrator.

The various actions to carry out to correctly configure the function relating to the switchboard are indicated below.

### 1. INSTALLER

- Connect a router to the IPerCom system network that can provide Internet access;
- Install IPerCom Installer Tools PC application;
- Create an Urmet Cloud account and authenticate with this account on the Urmet Cloud via the IPerCom Installer Tools application;
- Use the IPerCom Installer Tools application to create a system configuration and verify that the parameters of the call forwarding function are correct;
- Transfer the site to the building manager

### 2. BUILDING MANAGER

- Install the CallMe Manager application on PC;
- Create an Urmet Cloud account and authenticate with this account on the Urmet Cloud via the CallMe Manager application;
- Acquire site via the CallMe Manager app;
- Create letter (pdf format) with QR-code;
- Send letters via email or post to the switchboard operator.

### 3. USER (SWITCHBOARD OPERATOR)

- Install the CallMe application, distributed for Android and iOS operating systems and downloadable from the relevant stores (Urmet CallMe 2023 ed.);
- Create an Urmet Cloud account and authenticate with this account on the Urmet Cloud via the CallMe app;
- Scan the QR code sent by the building manager to associate the account to the switchboard;
- Check the switchboard shows the call forwarding icon.

## CONFIGURATION OF THE SYSTEM AND PARAMETERS OF THE CALL FORWARDING FUNCTION (INSTALLER)

Using the *IPerCom Installer Tools* application, the installer creates the project and the related configuration, that is defines the system topology, adds the devices on the topological nodes, assigns appropriate names to the devices, apartments, and topological nodes, creates the address books section of the configurator (as shown below):

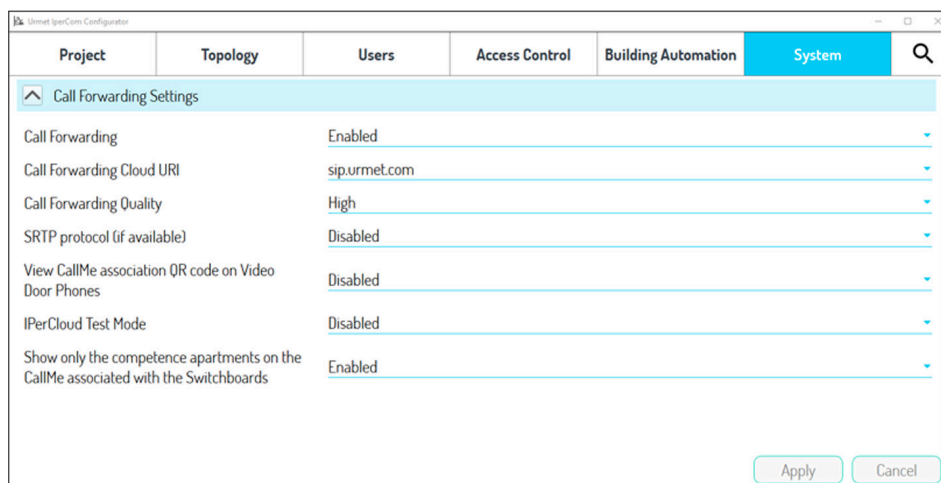

In correspondence with “*Call Forwarding*” item, check that the value is set to “*Enabled*”, as shown in the figure above.

In correspondence with the “*Call Forwarding Cloud URI*” item, it is necessary to set the server on which the user is registered via the CallMe app: the default server is “*sip.urmet.com*”, while the server “*sip.urmet.cn*” is to be used only for the Chinese market.

The “*Call forwarding quality*” item must be set based on the available bandwidth: if you encounter problems in the call, such as jerky video and/or incomprehensible audio, it is best to lower the quality of call forwarding call.

After creating the configuration, it is necessary to apply it to the system. To do this, you must first save the configuration and exit the configurator. Then select the “*Configuration*” tab and press the “*Apply changes*” button to transfer the configuration to the system:

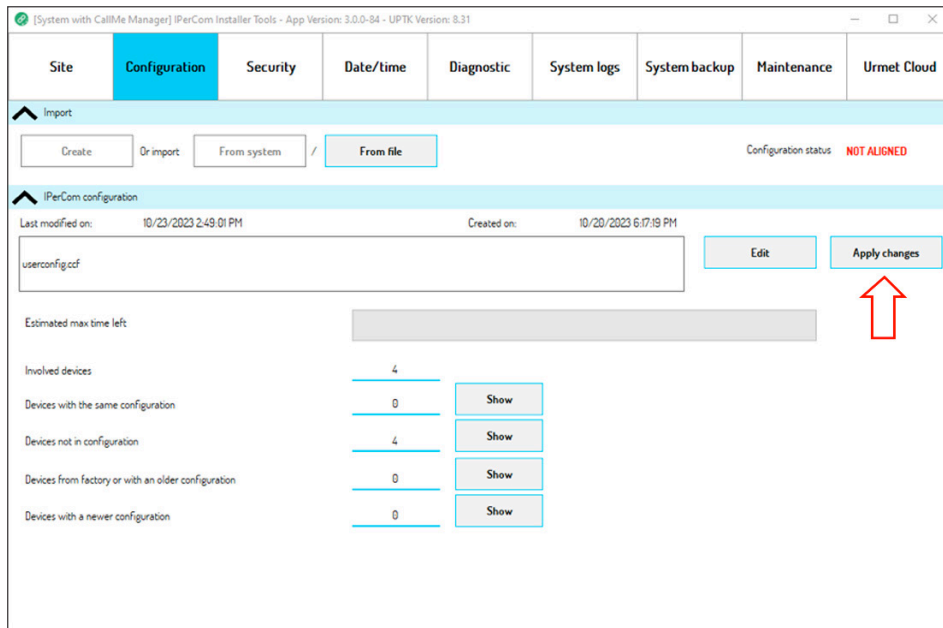

After this, it is necessary to go to the “*Urmet Cloud*” tab in the *Site authorization management* section:

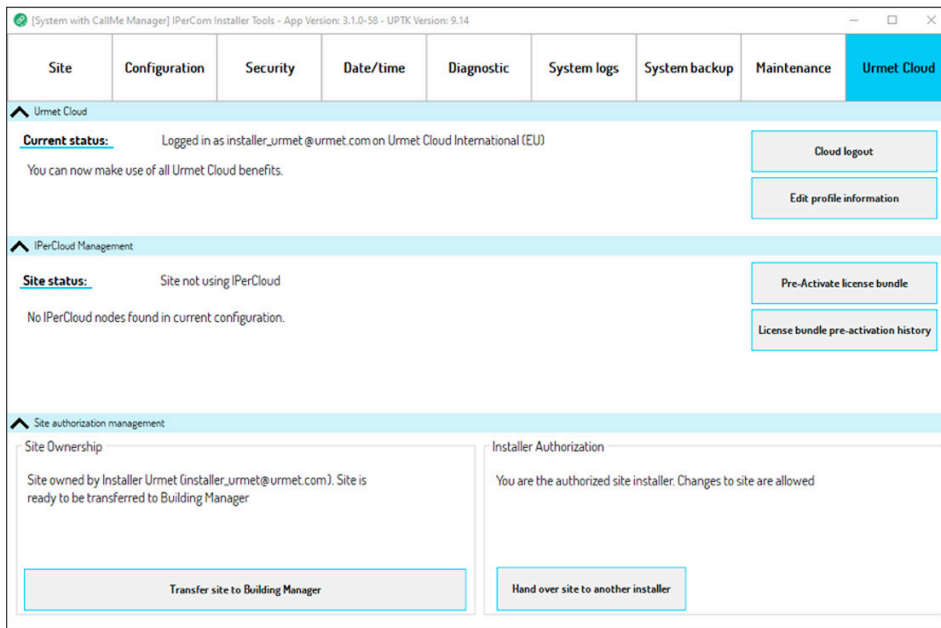

It is necessary to press the “*Transfer site to Building Manager*” button to transfer ownership of the site to the building manager, who with the CallMe Manager application will be able to configure the call forwarding service by printing the relevant letters. The following dialog box is shown in which it is necessary to enter the email with which the building manager registered with Urmet Cloud:

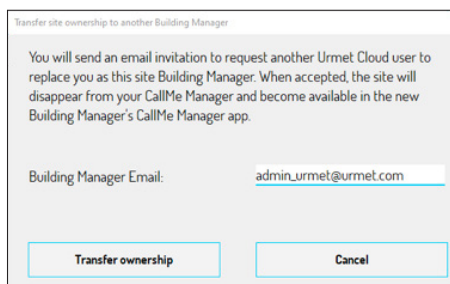

Premendo sul pulsante “*Invia all’Amministratore*”, una email è inviata all’amministratore e l’esito corretto della operazione è confermato dalla seguente finestra di dialogo:

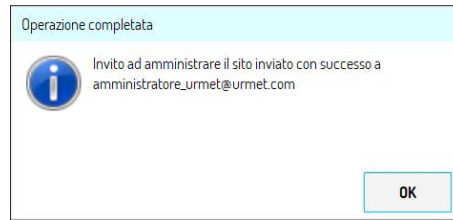

## IMPORT OF THE TOPOLOGICAL STRUCTURE OF THE SYSTEM AND PRINT OF LETTERS (BUILDING MANAGER)

The following are the basic steps that the building manager (via the CallMe Manager application) must follow to enable users to use the call forwarding function.

The CallMe Manager application and the relevant user booklet can be downloaded from the following address: <https://www.urmet.com/en-us/Professional/Tools/Software-and-Firmware> The CallMe Manager application allows:

1. generate the pdf file to send to switchboard operator to allow the association of account with Switchboard application for use of the call forwarding function;
2. manage the accounts of users who use the call forwarding function.

Before using the CallMe Manager application, the building manager must open the email that he received following the transfer of the site from the installer and press on the relevant link to make the transfer effective. The positive outcome of the operation is confirmed by the message “*Site acquired successfully*”.

At this point it is possible to start the CallMe Manager application, authenticate with the Urmet Cloud account previously created by the building manager and press the “*Login*” button:

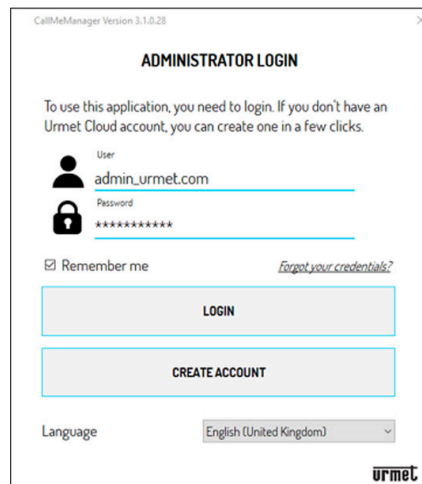

The CallMe Manager application shows the following dialog box relating to the presence of a new site (“System with CallMe Manager”) transferred to the building manager account:

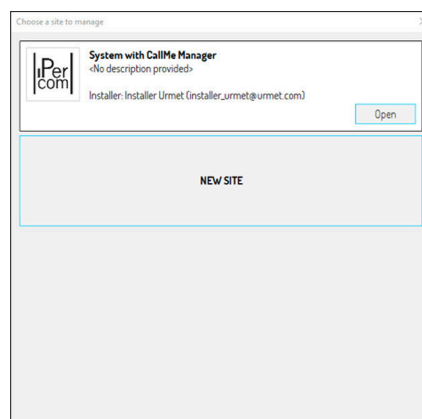

By pressing the “Open” button, the homepage of the *CallMe Manager* application appears with the new site loaded:

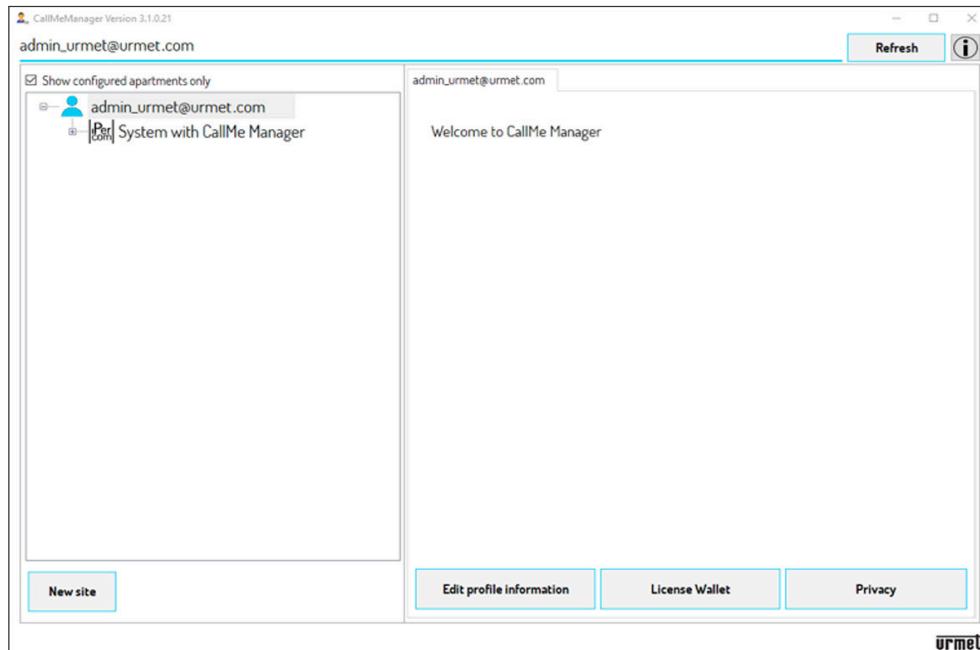

Expanding the topological structure, it is possible to display all the topological nodes on the system (i.e. blocks, stairs, floors and apartments) and the switchboard (positioned in this case on the topological node “Block 01”):

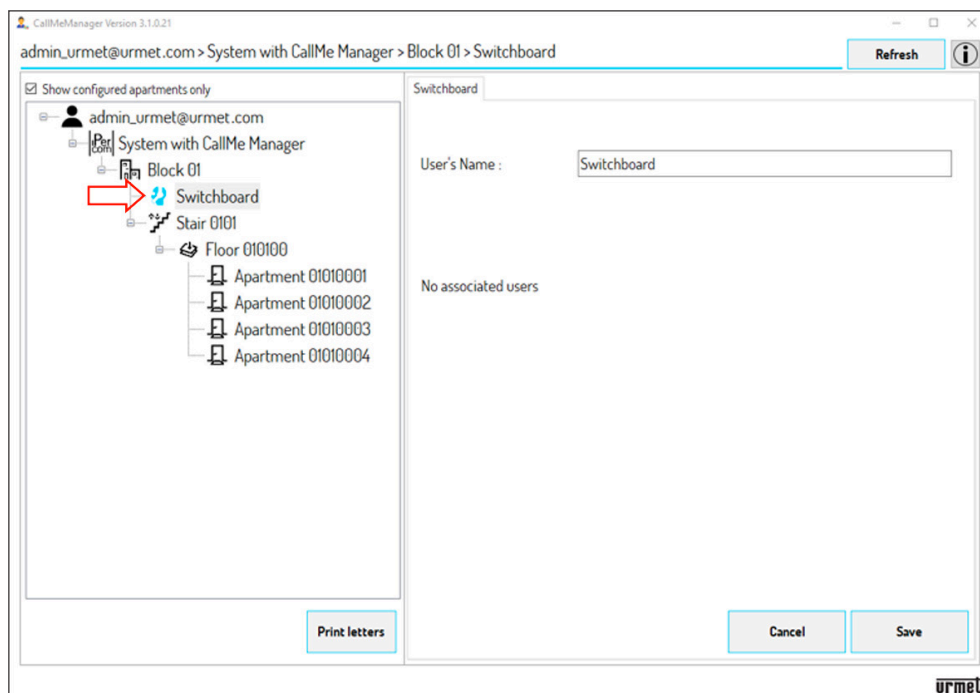

Once the topology has been imported, it is necessary to generate the letter (pdf file) that must be sent by mail or by post to the operator, to allow the association of the account with the switchboard (via the *CallMe app*) and use of the call forwarding function: to do so, after being positioned on the node relative to the switchboard, press the “**Print letters**” button.

The following screen appears:

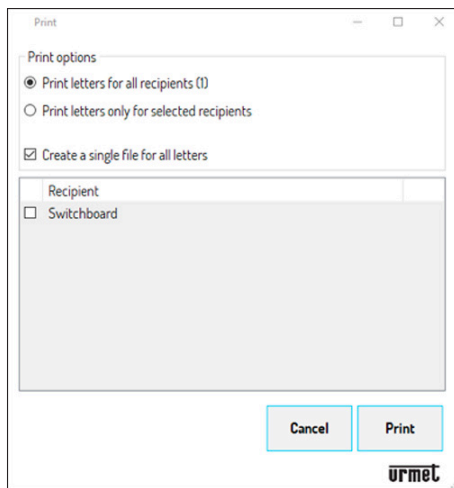

Press the “*Print*” button to generate the letter in PDF format to send to the switchboard operator.

### **ACTIVATE AND ENABLE THE CALL FORWARDING FUNCTION (SWITCHBOARD OPERATOR)**

The following are the basic steps the user must take with the CallMe app, after receiving a letter from the manager, to enable call forwarding on the switchboard.

For all information on configuring the CallMe app, refer to the [relevant booklet](#) on the website [www.urmet.com](http://www.urmet.com).

Scaricare e installare l'applicazione Urmec CallMe 2023 ed. dall'App Store (iOS) o dal Play Store (Android).

Launch the application and after viewing 4 the onboarding windows, press the “*Let's get started*” button.

The login page appears:

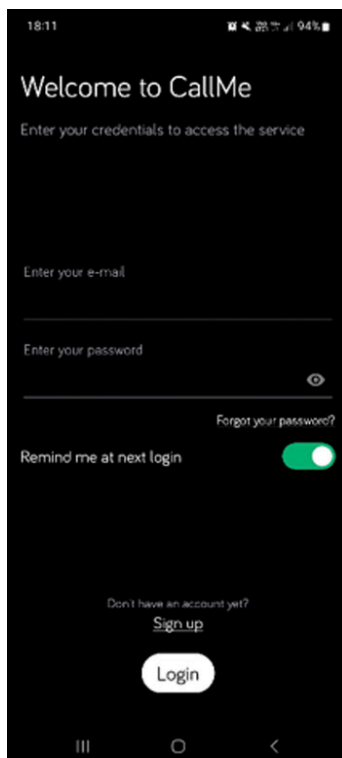

Once logged in with a newly created or existing account, the application homepage is displayed:

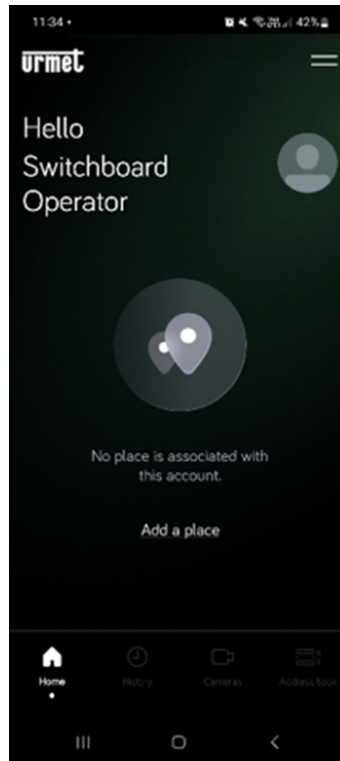

Pressing the “Add a place” button the following screen appears:

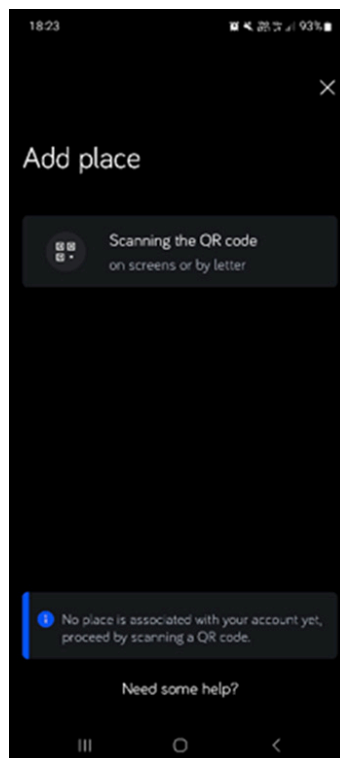

Press the “*Scanning the QR code*” button to start the QR Code Reader application, then scan the QR code displayed in the letter sent by the building manager. The app shows the following screen:

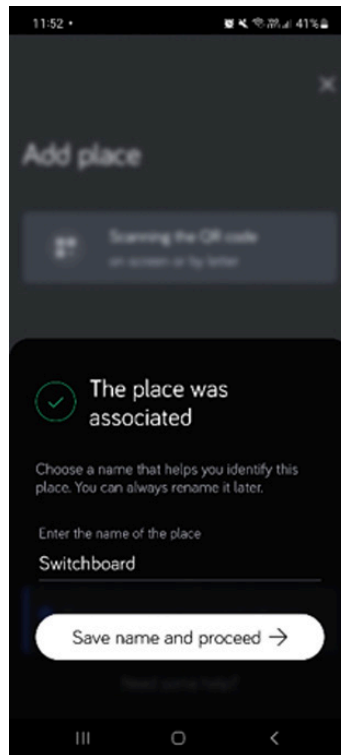

It is possible to change the name “*Switchboard*”. By pressing the “*Save name and proceed*” button, the home page of the CallMe application appears with the newly added “*Switchboard*” place:

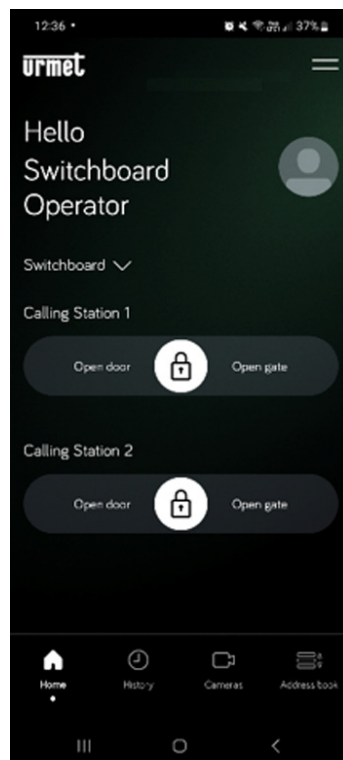

At this point there can be two ways to proceed, depending on whether the service is activated for the first time or not.

## Service activated for the first time

In the top bar on the Homepage, select the icon  and press the “Call forwarding” item The following window opens:

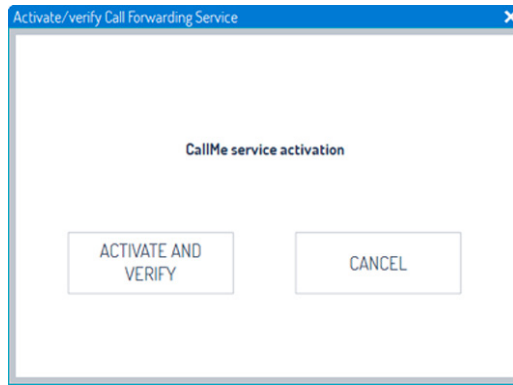

By pressing the “Activate and Verify” button, the correct outcome of the operation is indicated by the following pop-up window:

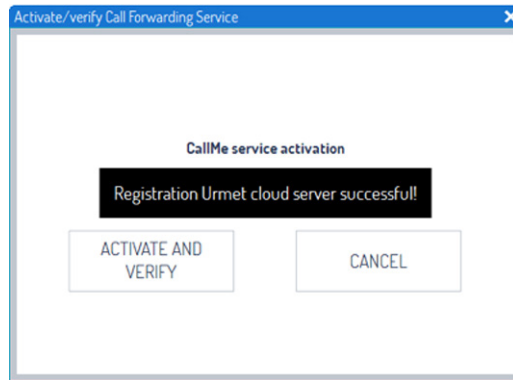

Then check that the icon , appears at the top right of the user interface, as shown in the figure below:



### Service not activated for the first time

In the top bar on the Homepage select the icon  and press the “Call forwarding” item. The following window opens:

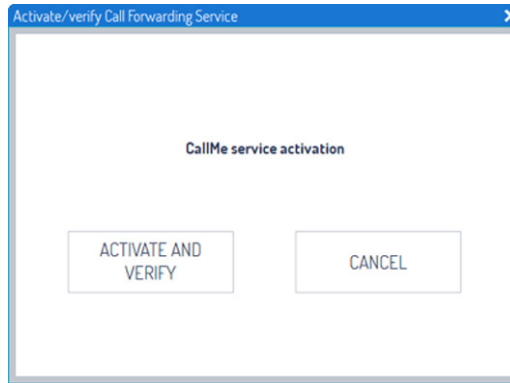

By pressing the “Activate and Verify” button, the correct outcome of the operation is indicated by the following pop-up window:

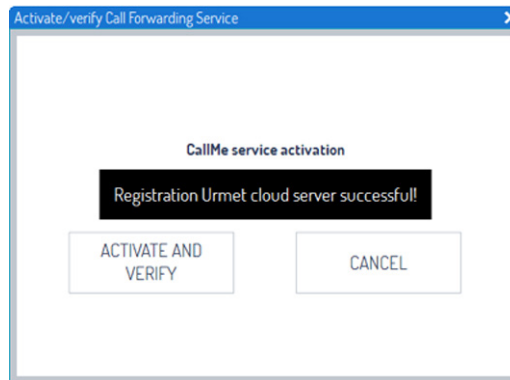

Lastly, to enable the call forwarding service, you must use the “Concierge Service Configuration” item and tick the “Call Forwarding” box.

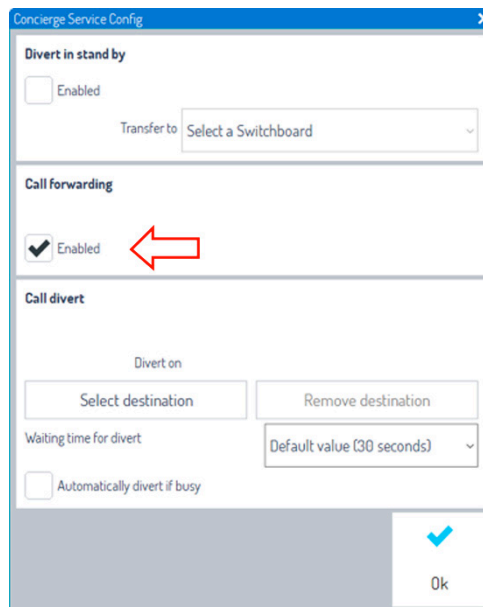

Pressing “OK” button, the icon  present in the upper left corner of the user interface, as shown above. At this point all calls to the switchboard are also forwarded to your smartphone/tablet from which you can answer and possibly open the door and gate.

In addition to call forwarding on smartphones/tablets (Android or iOS), the app CallMe also makes the following services available:

- auto on with mono or bidirectional audio on the system calling stations (“Cameras” button);
- display of missed calls from an apartment station (“History” button);
- display of alarm log (“History” button);

- make an emergency call to the apartment station from which the alarm has been received (“History” button);
- one-way and two-way auto-on function on Call Module 1060/12-13-17-18-23 following a tampering, coercion or forced door alarm (“History” button);
- one-way and two-way auto-on function on Modular Calling Station with 1060/48 for coercion or forced door alarm (“History” button);
- one-way and two-way auto-on function on Entry Panel 1060/71-74-75-78 for forced door alarm (“History” button);
- one-way and two-way auto-on function on Entry Panel 1060/21-33-34 for forced door alarm (“History” button);
- call only competence apartments (i.e. those in the topological group of the switchboard) or all apartments of the system depending on what was set in the configurator (“Address book” button);
- call other switchboards on the system (“Address book” button).

 *Auto on on RTSP cameras is not supported by CallMe app.*

For all information on configuring the CallMe app, refer to the [relevant booklet](#) on the website [www.urmet.com](http://www.urmet.com).

 *The QR code at the bottom of the pdf file or on the letter sent to the switchboard operator, once scanned, can no longer be used.*

 *Once the call forwarding function has been configured, it is of fundamental importance not to implement a new system configuration (even if the topology is the same): if so, the procedure seen above to associate the smartphone/tablet with the switchboard must be repeated.*

 *All the contacts created in the configurator on the topological path of Switchboard and with the CallMe option selected appear inside the “Address book” button too. For further details, see [manuale tecnico Ipercom ver. 3.2](#).*

 *If there are several switchboards in the system, you can call them all simultaneously and individually using the “Address book” button.*

 *If the CallMe application calls more than one switchboard and one of these rejects the call, it is also closed on the other switchboards and therefore also on the CallMe app. On the contrary, if an apartment station or a calling station calls more than one switchboard and one of these rejects the call, it is not terminated on the other switchboards.*

 *Calls to apartments and switchboards are forwarded only if the Switchboard application associated with the CallMe app is on and connected to the Internet.*

 *If the Switchboard application is placed on another topological node, it is not necessary to scan a new QR code.*

 *To remove the switchboard from the CallMe application, press the “Settings” → “My places” buttons in sequence. At this point, press on the item that identifies the Switchboard application, then on the “Manage this place” → “Delete” buttons and confirm with the “Delete” button.*

 *Missed calls (from apartment station) and alarms are notified even if the call forwarding function is not enabled.*

## APPENDIX B: CONFIGURING CALL FORWARDING FUNCTION IN IPERCOM SYSTEMS IN IPERCLLOUD MODE

Configuration of the call forwarding function relating to the switchboard in IPerCom systems in IPerCloud mode is similar to what is outlined in [APPENDIX A: Configuring the call forwarding function](#).

Once the site (created by the installer) in the CallMe Manager application has been acquired by the manager, after assigning licenses, it is enough to print the letters not only for IPerCloud apartments but also for the switchboard, positioning on the appropriate node according to the system topology.

For example, in the figure below you need to position yourself on the block node:

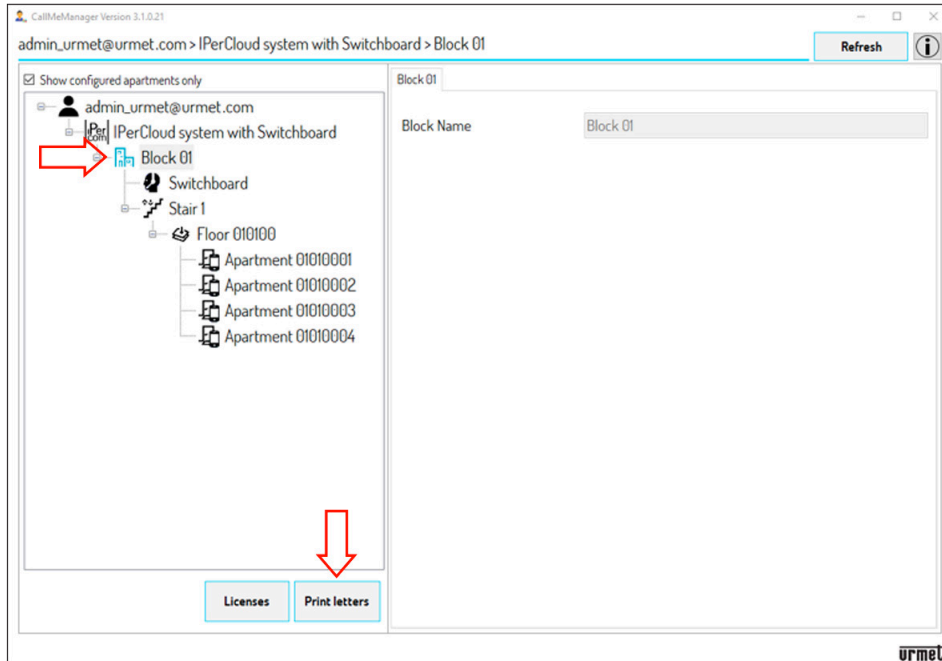

Pressing the “Print letters” button, both the IperCloud apartments and the switchboard are displayed:

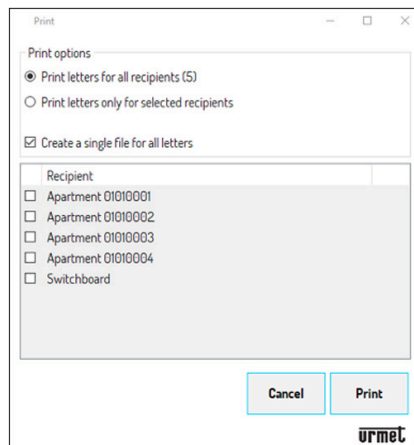

From this point on, the procedure is like what was seen in the case of configuring the call forwarding function with the support of the *CallMe Manager* application.

# APPENDIX C: CALL TO SEVERAL SWITCHBOARD APPLICATIONS EACH CONNECTED TO A CALLME APP

## CALL TO COMPETENCE SWITCHBOARD

If an apartment (or a calling station) calls more than one competence switchboard (each with the call forwarding function enabled) the only CallMe app that receives the call is the one linked to the switchboard placed on the lowest node of the topological path of the calling device.

Considering as an example a system with a topological structure like the one shown below:

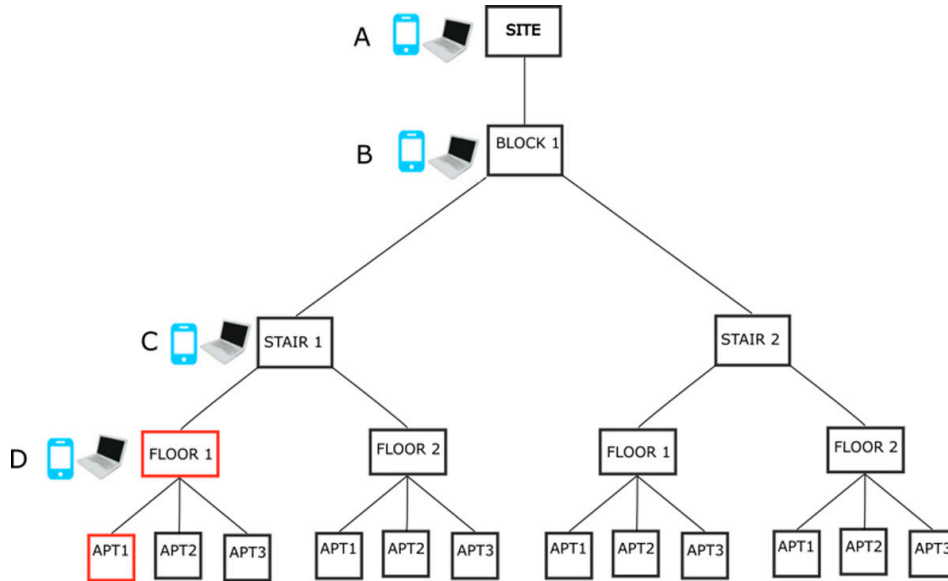

the apartment APP1 (in red) has relevant switchboards such as on the node “Floor 1”, “Stairs 1”, “Block 1” and “Site”. If the apartment APP1 calls the relevant switchboards, these ring simultaneously. If everyone is connected to their own CallMe app, the only one that receives the call is the switchboard one on the lowest node of the topological path of the apartment, i.e. (in the case shown in the figure) the CallMe app linked to the switchboard of the “Level 1” node (in red).

*If on the lowest node the Switchboard application is not linked to any CallMe app, the application that receives the call is the first one found on the nodes immediately higher (in the example above, the “Stair 1” node).*

If on the lowest node of the topological path of the call originator device (or in those immediately higher) there are several switchboards (each with the call forwarding function enabled), it is possible to determine via the *configurator* which CallMe app should receive the call.

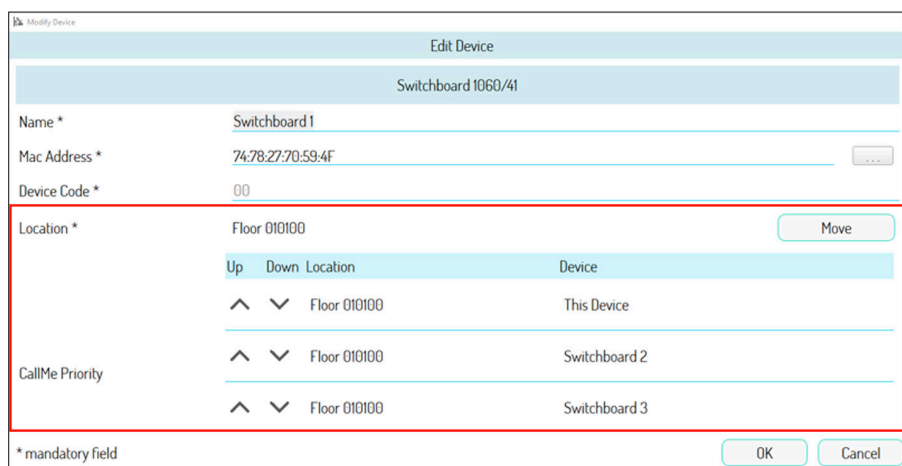

For example, if on the “Floor 1” node in the figure above there are 3 switchboards with the call forwarding function enabled, the list of switchboards present on the topological node in question appears on the configuration page of any of the 3 in the **CallMe Priority** section:



The list can be modified using the and buttons.

*“This Device” represents Switchboard 1, i.e. the switchboard whose configuration page has been opened via the configurator.*

The CallMe app associated with the first switchboard on the list (red box) is the one that will receive the call if the apartment APP1 calls the relevant switchboards. If you want another CallMe app to receive the call, you need to reorder the list and put in first place the switchboard connected to the CallMe app you want to ring.

-  If not all the switchboards on the same node are connected to the CallMe app, the ringing CallMe app is the one related to the first switchboard found in the list connected to the app.
-  The list will also show any other switchboards on other nodes of the same floor (level, stairs or block). These are not to be considered as they are not on the topological path of the call originator device.

### CALL TO ALL SWITCHBOARDS

If an apartment (or a calling station) calls from address book all switchboards of the plant (each one with the call forwarding function enabled) the only CallMe app that receives the call is the one linked to the switchboard placed on the highest node of the topological structure.

Considering as an example a system with a topological structure like the one shown below,

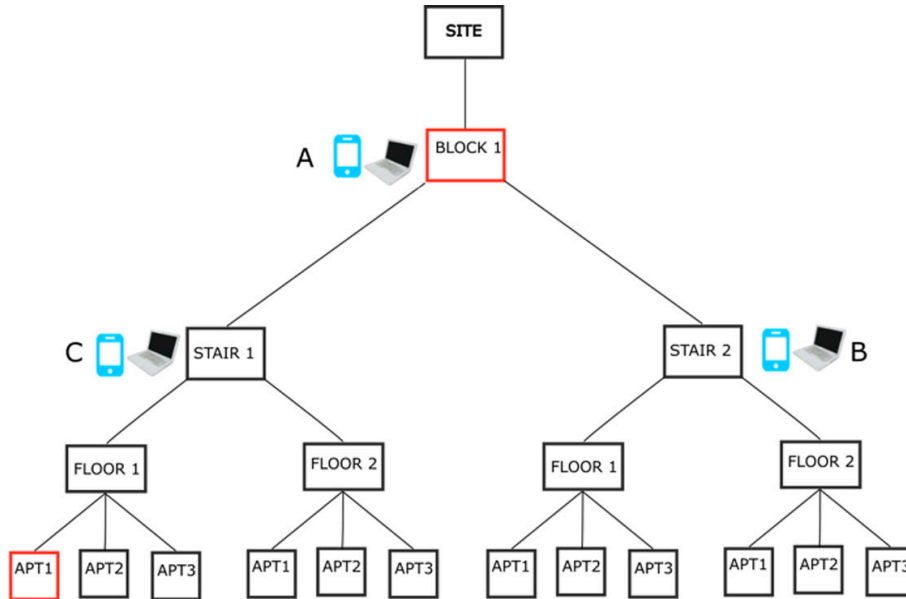



the APP1 apartment (in red) can call all the switchboards on the system from the address book, i.e. those on the “Stairs 1”, “Stairs 2” and “Block 1” node. These ring simultaneously, but if they are all connected to their own CallMe app, the only one that receives the call is the switchboard one on the highest node (in the case shown in the figure) the CallMe app linked to the switchboard of the “Level 1” node (in red).

If on the highest node there are several switchboards (each with the call forwarding function enabled), it is possible to determine via the *configurator* which *CallMe* app should receive the call.

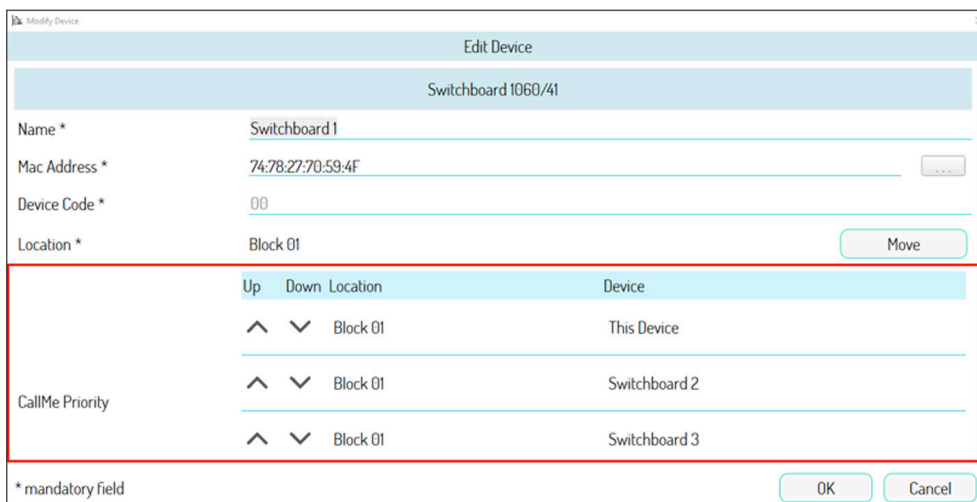
If there are 3 switchboards with the call forwarding function enabled on the “Block 1” node in the figure above, the list of switchboards present on the topological node in question appears on the configuration page of any of the 3 in the **CallMe Priority** section:



The list can be modified using the  and  buttons.

 “This Device” represents Switchboard 1, i.e. the Switchboard application whose configuration page has been opened via the configurator.

The *CallMe* app associated with the first Switchboard application in the list (box in red) is the one that will ring after a call to all switchboards. If you want another *CallMe* app to ring, you need to reorder the list and put the Switchboard application connected to the *CallMe* app you want to ring in the first place.

 In the event that not all Switchboard applications of the “Block 1” node are connected to the *CallMe* app, the *CallMe* app that rings is the one relating to the first Switchboard application found in the list and connected to the app.

 In general, any other Switchboard applications present on the other nodes of the same level (floor, stair and block) will also appear in the list. These (if connected to a *CallMe* app) are to be taken into consideration as the call is directed to all switchboards in the system.

## HOW TO MAKE MULTIPLE CALLME APPS RING AFTER A CALL TO THE COMPETENCE SWITCHBOARD

Following a call to the competence switchboard, it is possible to make multiple *CallMe* apps ring by sharing access to the system (place) with other users. Considering as an example a system with a topological structure like the one shown below,

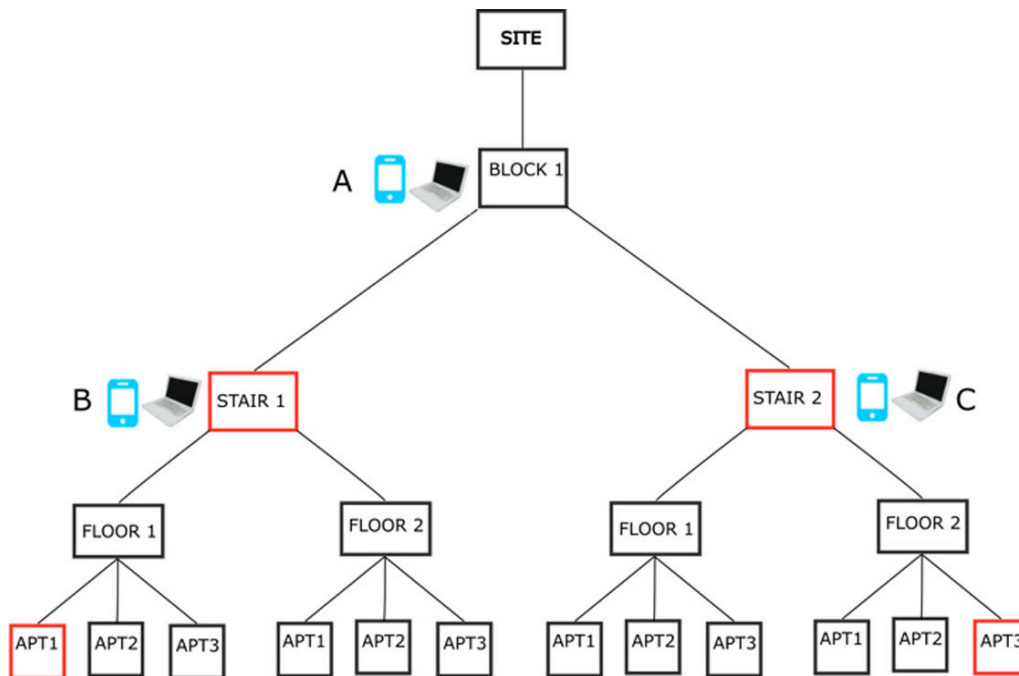

APT1 apartment (in red) has as competence switchboards those on the “Stair 1” and “Block 1” nodes and in the same way APT3 apartment (in red) has as competence switchboards those on the “Stair 2” and “Block 1” nodes. If the apartment APP1 calls the relevant switchboards, these ring simultaneously and the only *CallMe* app that receives the call is the switchboard on the lowest node of the topological path of the apartment, i.e. (in the case shown in the figure) the *CallMe* app linked to the “Stairs 1” node switchboard (in red). Similarly for the APP3 apartment, the *CallMe* app that rings is the one linked to the switchboard of the “Stairs 2” node (in red).

If you want to ensure the *CallMe* app linked to the “Block 1” node switchboard also receives the call from APP1 (for example), the user authenticated on the *CallMe* linked to the switchboard of the “Stairs 1” node (Switchboard “B”) shares the system (place) with the authenticated user on *CallMe* linked to the “Block 1” node switchboard (“Switchboard A”).

To do this it is necessary to:

- have smartphones / tablets A and B available (see figure above);
- have logged in with a valid account on both smartphones.

At this point follow the instructions below:

- With smartphone B from home page of *CallMe* app press in sequence buttons “Settings” () → “My places” → “Switchboard B”:

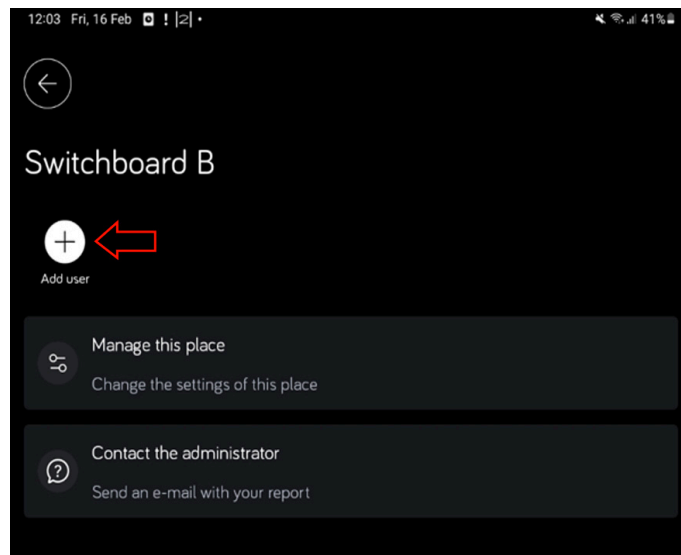

- Press on button “Add user” (red arrow):

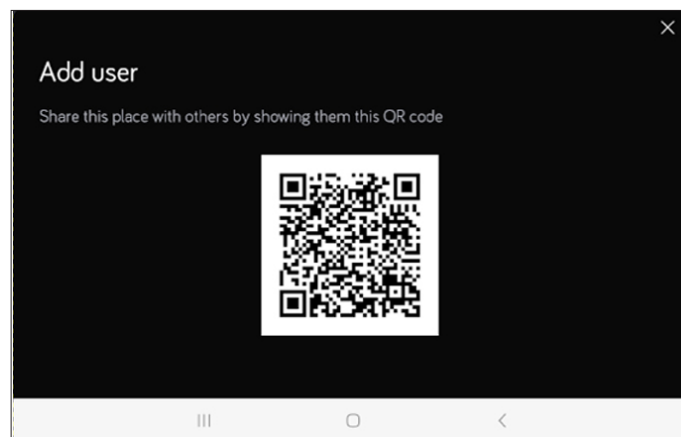

On smartphone/tablet A it is necessary:

- Press in sequence buttons “Settings” (☰) → “My places”:

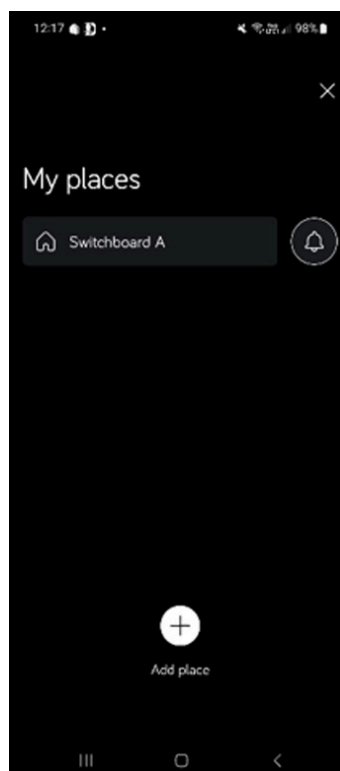

- press then the button “Add place”:

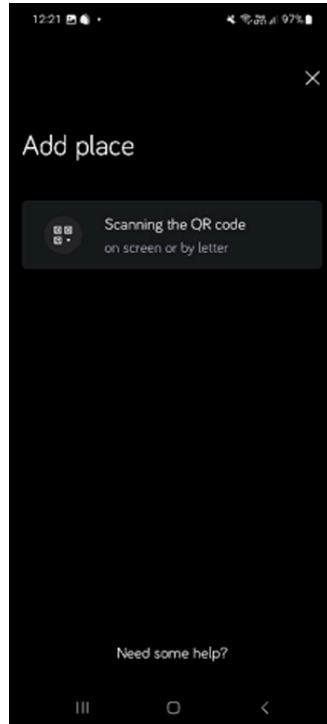

- press the “Scanning the QR code” button, scan the QR code generated on the smartphone/tablet B and press the “Save name and proceed” button in the relevant dialog box:

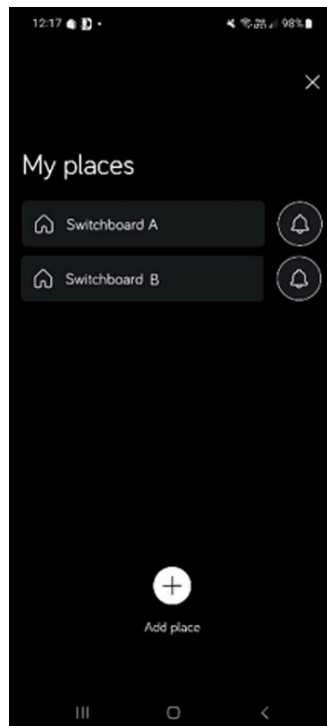

The relevant location of the switchboard in the “Stairs 1” node (“Switchboard B”) appears on the CallMe application linked to the switchboard of the “Lock 1” node (“Switchboard A”).

A call from APT1 to the competence switchboards will make ring the two CallMe apps of the “Stair 1” and “Block 1” nodes.

The same procedure can be done on smartphones/tablets C and A, so that if APT3 calls the competence switchboards, the call is received both by smartphone/tablet C and by smartphone/tablet A.